

TOSHIBA MACHINE

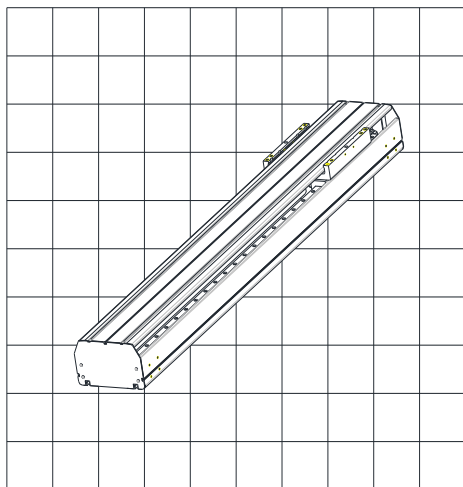

ROI BOT
BA-III SERIES

MODEL : BE60
Straight axis

ACTUATOR INSTRUCTION MANUAL

TOSHIBA MACHINE CO., LTD.

Keep this manual nearby for future reference.

Introduction

Before using the ROIBOT BA-III series, read through and completely understand this instruction manual to assure correct use.

For general information for the ROIBOT Arm BAIII Series, refer to CA25 Instruction Manual (Basic Part).

CAUTION

1. The contents of this manual are subject to change without prior notice.
2. The contents of this manual are subject to change without prior notice to effect improvements.
3. All efforts have been made to assure the contents of this manual. If you have any questions, or find any mistakes, however, please contact Toshiba Machine.
4. Toshiba Machine will not be held responsible for any effects caused by using this equipment, regardless of Item 3 above.
5. This equipment does not have an explosion-proof structure. Take utmost care of the operating environment.

Table of Contents

- Chapter 1 Safety..... 1
 - 1.1 Cautions for safety..... 1
 - 1.2 For your safe operation.....5
 - 1.3 Warranty.....8
- Chapter 2 Shipment List..... 10
 - 2.1 Shipment list..... 10
- Chapter 3 Axis Specifications 11
 - 3.1 Axis type and names of individual parts 11
 - 3.2 Single axis specification..... 12
- Chapter 4 Installing Actuator (Axis)..... 18
 - 4.1 Installing Actuator (Axis) 19
 - 4.2 Robot type for each Axis 19
 - 4.3 Parameter values 20
- Chapter 5 Maintenance..... 22
 - 5.1 Precautions for inspection and maintenance work 22
 - 5.2 Inspection before starting the work 23
 - 5.3 Periodic inspection 23
 - 5.4 Greasing..... 24
 - 5.5 Cleaning 25
 - 5.6 Motor replacement procedure..... 25
 - 5.7 Origin position adjustment 27
 - 5.8 Replacement of ball screw..... 28
 - 5.9 Replacement of linear guide 28
- Chapter 6 Spare Parts 29
 - 6.1 Maintenance 29

Overview

- This manual describes the axis type expression method, specifications and motor replacement procedures, etc., according to the type of axis.
- For the installation, see the instruction manual (installation of actuator) provided separately.

Chapter 1 Safety

■ 1.1 Cautions for safety

- Before the installation, programming, operation, maintenance and inspection of the equipment, be sure to read through this manual so that you can use the ROIBOT with safety.
- After you have read this manual, keep it nearby for future reference.

Be sure to observe the instructions for ensuring operation safety of the ROIBOT.

This manual contain the important information to prevent injury to the operators and persons nearby, to prevent damage to assets and to assure correct use of the equipment.

Make sure that you have well understood the following details (indications and symbols) before reading this manual. Always observe the information that is noted.

⚠ WARNING : If you have neglected this instruction and caused a handling error, death or serious injury may occur.

⚠ CAUTION : If you have neglected this instruction and caused a handling error, human injury or property damage (damages to houses, household goods and domestic animals) may occur.

CAUTION : This gives a brief description of the major points of operation procedures, precautions and method for effective use of the machine.

⚠ WARNING

- **Install the safety fences to prevent anyone from entering the working envelope of the robot.**

When the door is attached to the safety fence, the robot should be stopped at emergency at the same time that the door has opened.

- **Connect the EMERGENCY STOP pushbutton switch to the emergency stop input terminal of the controller and mount the same switch at an easy-to-operate place in an emergency.**

The EMERGENCY STOP switch must not be reset automatically and cannot be reset negligently by any person.

- **Wiring should be done safely and completely according to the Electrical Installations Technical Requirements and Interior Wiring Requirements of Japan.**

Incorrect wiring will result in an electric shock or a fire.

- **The equipment MUST NOT be repaired or modified without prior written permission from the manufacturer.**

Otherwise, an accident or damage will be caused.

- **Before the maintenance and inspection, be sure to turn off the controller main power switch. Take all necessary measures to prevent anyone other than the worker engaged in adjustment of the robot from negligently turning the power on. (Lock the switch and put a tag showing "DO NOT turn the power on.") Also, DO NOT touch the controller interior three (3) minutes after the power is turned off.**

Otherwise, you may get an electric shock due to residual voltage of the capacitor.

- **DO NOT touch the motor, heat sink and cement resistor in the controller.**

They are too hot and you may get burnt. Before performing inspection, take enough time to cool them off.

- **DO NOT pour water on the equipment interior or exterior, or drain water from it. Otherwise, you may get an electric shock, or the equipment will be damaged.**

When the equipment has contaminated, wipe it off with a hard squeezed cloth. DO NOT use a thinner, benzine or other organic solvent.

- **DO NOT throw away metals, combustibles or other contaminant into the opening of this equipment.**

A fire or an electric shock will be caused.

- **DO NOT put your finger or hand on the movable part or opening of the equipment.**

Otherwise, you may get injured.

- **When using the actuator in other than the horizontal state, be sure to select the actuator with brake.**

Otherwise, the slider will drop at power OFF, and you will be injured.

⚠ WARNING

- **As the equipment is heavy, make sure of its weight and gravity center position and disconnect the cables when carrying the equipment.**

Also, DO NOT carry the equipment with the slider. Otherwise, the slider will move and you will get injured.

- **DO NOT use this equipment for the living body as a massaging machine.**

Otherwise, you will be injured due to incorrect teaching or mis-operation.

- **This equipment has not a sealed structure. During use, grease of the ball screw or wear of the belt may scatter from the opening of the equipment.**

When using this equipment for food and chemical applications, take appropriate measures against entry of them.

- **Enter the robot type and initialize the memory correctly.**

Otherwise, the robot may move unexpectedly and you will be injured.

- **DO NOT use this equipment in an atmosphere of inflammable gas or an atmosphere inducing an explosion.**

As this equipment is not explosion-proof, it may explode in the worst occasion.

- **DO NOT damage, break, process, forcibly bend, stretch, place a heavy object on or pinch the cables (power cable, controller cable).**

Otherwise, an electric shock or a fire will be caused.

- **Should an abnormality such as smoke or nasty smell occur, turn the power off immediately and stop using the equipment.**

If the equipment is used continuously, an electric shock or a fire will be caused.

When using the side mounted motor axis in the vertical condition, be sure to check for the belt on a regular basis. Replace the belt every 3,000-hour operation.

If the belt whose service life already ended is used continuously, it may be broken or the slider may drop, and you will be injured.

⚠ CAUTION

- **DO NOT place the equipment at a place where the ambient temperature exceeds 40°C, or where the temperature changes sharply, causing condensing, or where it is exposed to direct sunlight.**

Additionally, if the equipment is installed at a narrow place, the ambient temperature rises due to heat generation in the controller itself or external device, which will result in malfunction or mis-operation of the equipment.

- **DO NOT use the equipment at a place where an impact or vibration is involved. Also, DO NOT use the equipment in an atmosphere where conductive dust, corrosive gas or oil mist generates.**

Otherwise, a fire, electric shock, malfunction or mis-operation will be caused.

- **DO NOT use the equipment at a place where too much dust or dirt exists.**

If the equipment is used at such a place, it may malfunction because this equipment is not dust-proof.

- **DO NOT use repair parts other than those designated by the manufacturer.**

Otherwise, the equipment cannot be operated to its full capacity and will cause malfunction.

- **Mount the robot on a highly rigid frame.**

If rigidity of the frame is not enough, vibration (or resonance) may be caused during the robot operation, adversely affecting the operation.

■ 1.2 For your safe operation

When you use the ROIBOT BE Series, be sure to take the measures in conformity to the following instruction:

This machine is an industrial robot in conformance to the provisions of Paragraph 31 of Article 36 of the Ordinance on Industrial Safety and Hygiene. Necessary cautions are specified in the "Selection", "Installation", "Use", "Periodic Inspection, etc." and "Education" of the "Technical Guideline on Safety Standards for Use of Industrial Robot" conforming to the Article 28 of the Industrial Safety and Health Law. You are requested to read them carefully and to observe the instructions. The following introduces some of them.

■ 1.2.1 Safety measures

(1) A safety barrier shall be provided to ensure that any person cannot enter the working area of a robot.

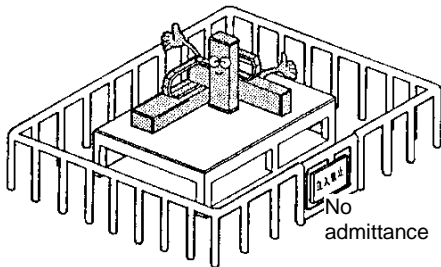

1. The barrier shall have sufficient strength to withstand the force generated during the work or environmental conditions. The barrier shall have such a structure that cannot be easily adjusted, removed or cleared.
2. The safety barrier shall be free from any serrated or sharp edge or protrusions.
3. The safety barrier shall be designed in a stationary structure.
4. When a safety barrier is equipped with a door, an interlock shall be provided so that the robot will be stopped by opening of the door.

(2) An emergency stop device shall be installed where the robot can be easily stopped by the operator immediately in the event of emergency.

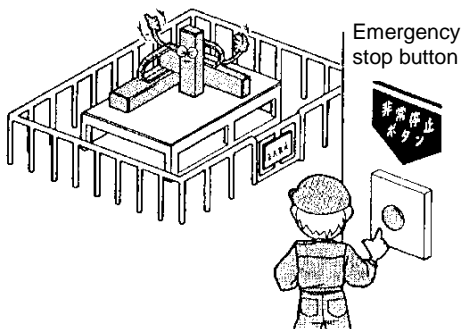

1. The emergency stop function shall ensure immediate and reliable stop of a robot when the emergency stop button switch has been operated by an operator.
2. The emergency stop button shall be red.
3. The emergency stop device shall be located so that it can be easily pulled, pressed or touched by the operator, and it can block a beam of light.
4. The emergency stop button shall be structured in such a way that it is not automatically reset after having been operated, and cannot be reset carelessly.

(3) For safety, never modify the robot main unit or control device.

■1.2.2 Precautions for installation

Observe the following instructions when installing a robot:

- (1) The robot shall be laid out to ensure the work space required for robot teaching, maintenance and inspection.
- (2) The robot controller, other controllers and stationary operation panel shall be installed outside the movable range and where the operator can watch the robot operations.
- (3) The pressure gauge, hydraulic pressure gauge and other instruments shall be installed in clearly visible positions.
- (4) The electric wiring and hydraulic/pneumatic piping shall be provided with protective covers if they may be damaged.
- (5) To ensure effective operation of the emergency stop device in the event of emergency, emergency stop device switches shall be installed on locations other than the operation panel, as required.

■1.2.3 Precautions for use

Observe the following instructions when using a robot:

[Work within the movable range]

- (1) Work provisions
 - Determine provisions for the following items and perform the work in conformity to them:
 1. Root operation methods and procedures required in the work such as startup method and switch handling method.
 2. Speed of robot main unit in teaching.
 3. Signaling method for work adjustment among more than one operator.
 4. Action to be taken by the operator for each problem.
 5. Procedures for confirming the release of the emergency and safety when restarting the robot operation after the robot operation has been stopped due to the operation of the emergency stop device.
 6. Measures to protect against the hazard due to unexpected operation of the robot described below (in addition to the above items), or the hazard caused by a robot operation error.
 - Indication on the operation panel.
 - Measures to ensure safety of the operator working within the movable range.
 - Working position and posture.
 - Prevention of operation error due to noise.
 - Signaling method for work adjustment with operators of related devices.
 - Error type and evaluation procedure.
 7. The work provisions shall meet the requirements of the robot type, installation site and work.
 8. The work provisions shall be prepared by consultation with the related operators, manufacturer's engineers and industrial safety consultant.
- (2) Indication on the operation panel
 - To ensure that the start switch and selector switch will not be carelessly operated by a person other than the personnel in charge of this work, the switch shall be provided with an easy-to-read indication to show that the work is in progress. Alternatively, the operation panel cover shall be provided with locking or other means.
- (3) Measures to ensure the operation safety of the personnel working within the movable range
 - Any one of the following measures or other measures on the equal or higher level shall be taken so that you can stop the robot operation immediately in the event of an error when working within the movable range:

1. An adequately authorized supervisor shall be assigned outside the movable range and where the robot operations can be observed. This supervisor shall be exclusively in charge of the supervision and shall be responsible for the following:
 - The supervisor shall cause the emergency stop device to be operated immediately in the event of an error.
 - The supervisor shall ensure that a person other than the personnel in charge of this work is kept outside the movable range.
2. The emergency stop device switch shall be placed under the control of the person working within the movable range.
3. A portable operation panel having a structure capable of on/off operation of the power source, oil hydraulic or pneumatic source shall be used in the work.
- (4) Inspection prior to start of the work such as teaching

Prior to start of the work such as teaching, the following items shall be inspected. If any error is detected, immediately repair the trouble or take other required action.

 1. Check if the covering or sheathing of the external power source is damaged or not. (This check must be made after the power has been turned off).
 2. Check if the operation of the robot proper is faulty.
 3. Check for the functions of the braking device and emergency stop device.
 4. Check if there is any leakage of air or oil from the piping.
- (5) Cleaning of working tools

When such working tools as a painting nozzle are mounted on the robot proper, and these working tools must be cleaned, it is preferred that these tools should be automatically cleaned so that the number of machines entering the movable range can be minimized.
- (6) Release of residual pressure

Before disassembling the pneumatic components or replacing their parts, release the residual pressure in the drive cylinder.
- (7) Operation check

Perform the verification operation without entering the movable range, wherever possible.
- (8) Illuminance

The illuminance required for operation safety shall be maintained.

[For automatic operation]

- (1) Action before startup

Before starting the robot, check for the following items in advance and determine a signaling method for work adjustment among related operators.

 1. Make sure that there is no person within the movable range.
 2. The movable operation panel and tools shall be located at specified positions.
 3. There shall be no error indication for the robot or related devices.
- (2) Action for automatic operation and in the event of an error
 1. Make sure that there is an indication to show that the automatic operation is now in progress, after the robot has been started.
 2. When a problem has occurred to the robot or related device and you have to enter the movable range to take emergency measures, stop the robot operation, for example, by operating the emergency stop device before entering the movable range. At the same time, carry a safety plug with you, and ensure that the start switch is provided with the indication to show that the work is now in progress. Take measures so that any other person than the operator in charge of the emergency measures cannot operate the robot.

Requesting your cooperation

For the safety instructions which seem especially important, relevant warning label is attached to the equipment.

When the label attached to the equipment has peeled off or the characters are defaced and unreadable, please procure it from our sales agent in your territory by specifying the part number, and attach it to the original place.

Warning label for actuator

Part number: 55620157

 WARNING	<ul style="list-style-type: none">• Before the installation, programming, operation, maintenance and inspection of the equipment, be sure to read through this manual so that you can use the ROIBOT with safety.• Install the safety fences to prevent anyone from entering the working envelope of the robot.• DO NOT put your finger or hand on the movable part or opening of the equipment. Otherwise, you may get injured.• When using the actuator in other than the horizontal state, be sure to select the actuator with brake. Otherwise, the slider will drop at power OFF, and you will be injured.
--	--

■ 1.3 Warranty

■ 1.3.1 Warranty period

This product is warranted for one of the following periods whichever comes first.

- (1) For 24 months after shipment from our factory.
- (2) For 18 months after installation at the customer's factory.
- (3) For 4000 hours of operation.

■ 1.3.2 Details of warranty

- (1) This product is warranted. The scope of the warrant includes the specifications and functions described in the Specification, catalog and Instruction Manual. We are not responsible for any secondary or incidental damages caused by the trouble of this product.
- (2) We will repair, on a free-of-charge basis, the trouble caused in the handling or use of the product within the warranty period of this product as described in the Instruction Manual attached to this product. Alternatively, such trouble will be repaired after the product has been returned to our factory. If the problem is solved by a dispatch of service personnel to meet the convenience of the customer, we may claim payment from your company regarding the transportation expenses, lodging expenses or other expenditures not directly related to the repair of the product.

■1.3.3 Exemption from responsibility

The following cases shall be excluded from the scope of warrant.

- (1) The trouble and damage caused by the use of the product according to a method not described in the Instruction Manual, or by a careless error in use.
- (2) Problems caused by chronological changes or wear by use (such as natural fading of paints, deterioration of the consumable parts ^{*1}).
- (3) Problems caused by sensory phenomena (e.g. generated noise without affecting the function).
- (4) Modification or disassembling not authorized by our company.
- (5) Troubles or damages caused by inadequate maintenance and inspection or improper repair.
- (6) Troubles or damages caused by natural disaster, fire and other external factors.
- (7) Internal data such as programs and points created or modified by the customer.
- (8) Problems caused when this product purchased in Japan is brought to an overseas country.

*1 : Consumable parts are defined as the parts maintenance replacement parts (spare parts) described in the Instruction Manual of each product, and the parts (e.g. backup battery) that must be replaced on a periodic basis.

■1.3.4 Precautions

- (1) When you have used the product beyond the specifications of the product, we cannot warrant the basic performances of the product.
- (2) Should you fail to observe the instructions given in "WARNING" and "CAUTION" described in the Instruction Manual, we are not responsible for any personal injury, damages or trouble that may occur.
- (3) Please note that the "WARNING" and "CAUTION" described in the Instruction Manual, and other descriptions are within the scope assumed by our company.
- (4) The numerical values given as technical data are theoretical values as a guideline showing the durability and others. They shall not be construed as indicating warranty. Note that these values are subject to change according to the conditions of use.

Chapter 2 Shipment List

■2.1 Shipment list

When the axis proper is shipped, it is composed of the following parts:

- (1) Actuator(axis)
- (2) Number of oval bolts attached (M8×40)
 - The above-mentioned axis-1 will be provided with the bolts in the number shown in the right-hand Table.



Axis stroke (mm)	Attached quantity
150~200	12
250~600	16
650~1000	20
1050~1300	26
1350~1700	32

- (3) Actuator Instruction Manual (this Manual)

Chapter 3 Axis Specifications

3.1 Axis type and names of individual parts

■ Type of axis

The following shows the axis type:

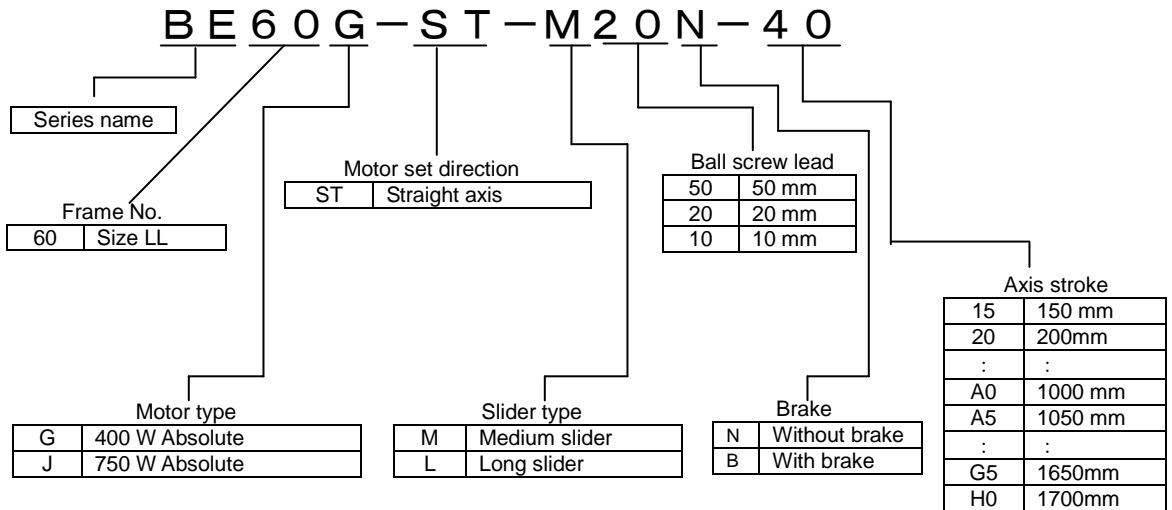

■ Names of individual parts

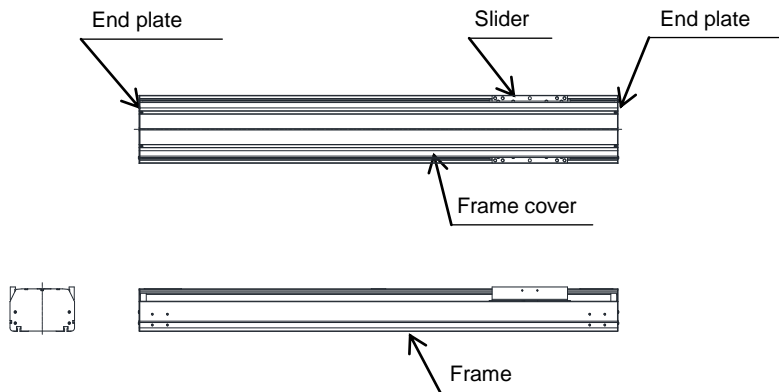

3.2 Single axis specification

Specifications

Axis type BE60G-□□-□□□□-□□

Motor		AC 400-watt servo motor absolute		
Drive method		Ball screw $\phi 20$ Lead 20 mm Lead 10 mm		
Guide method		Linear guide (Double) Bearing block ... 4 pieces		
Maximum payload mass (Note 1) (Note 2)	Ball screw lead	Horizontal	Vertical	
	20 mm	100 kg	25 kg	
	10 mm	150 kg	50 kg	
Maximum speed (Note 3)	Ball screw lead 20 mm	1200 mm/s		
	Ball screw lead 10 mm	600 mm/s		
Static permissible moment (Note 4)	Medium slider	MR:2700 N·m	MP:3000 N·m	MY:2250 N·m
	Long slider	MR:2700 N·m	MP:4750 N·m	MY:3450 N·m
Repeated positioning accuracy		± 0.01 mm		
Resolution		0.01 mm		
Rated thrust	Ball screw lead 20 mm	400 N		
	Ball screw lead 10 mm	800 N		

(Note 1) A regenerative electric discharge unit is required, irrespective of the master power voltage and load mass.

(Note 2) This indicates the value when the acceleration/deceleration time is 0.36 s or more.

(Note 3) The maximum speed will be as follows, depending on the axis stroke.

Stroke range	Maximum speed	
	Lead 20 mm	Lead 10 mm
700 mm or less	1200 mm/s	600 mm/s
750~800 mm	1000 mm/s	500 mm/s
850~900 mm	800 mm/s	400 mm/s
950~1000 mm	700 mm/s	350 mm/s
1050~1100 mm	600 mm/s	300 mm/s
1150~1200 mm	500 mm/s	250 mm/s
1250~1300 mm	400 mm/s	200 mm/s
1350~1500 mm	300 mm/s	150 mm/s

(Note 4)

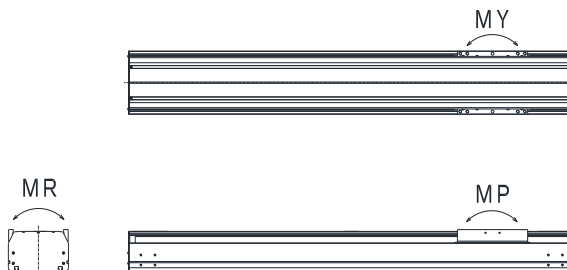

MR: Rolling Moment
MP: Pitching Moment
MY: Yawing Moment

Axis type BE60J-□□-□□□□-□□

Motor		AC 750-watt servo motor absolute	
Drive method		Ball screw $\phi 20$ Lead 50 mm Lead 20 mm Lead 10 mm	
Guide method		Linear guide (Double) Bearing block ... 4 pieces	
Maximum payload mass (Note 1) (Note 2)	Ball screw lead	Horizontal	Vertical
	50 mm	50kg	—
	20 mm	200kg	50kg
	10 mm	250kg	100kg
Maximum speed (Note 3)	Ball screw lead 50 mm	2300mm/s	
	Ball screw lead 20 mm	900mm/s	
	Ball screw lead 10 mm	600mm/s	
Static permissible moment (Note 4)	Medium slider	MR:3500N · m	MP:4000N · m MY:3000N · m
	Long slider	MR:3500N · m	MP:6200N · m MY:4750N · m
Repeated positioning accuracy		± 0.01 mm	
Resolution		0.01 mm	
Rated thrust	Ball screw lead 50 mm	300N	
	Ball screw lead 20 mm	750N	
	Ball screw lead 10 mm	1500N	

(Note 1) A regenerative electric discharge unit is required, irrespective of the master power voltage and load mass.

(Note 2) This indicates the value when the acceleration/deceleration time is 0.27 s or more.

(Note 3) The maximum speed will be as follows, depending on the axis stroke.

Stroke range	Maximum speed	
	Lead 20 mm	Lead 10 mm
1000mm or less	2300mm/s	900mm/s
1050~1100mm	1800mm/s	700mm/s
1150~1200mm	1500mm/s	600mm/s
1250~1300mm	1300mm/s	500mm/s
1350~1500mm	1000mm/s	400mm/s
1550~1700mm	800mm/s	300mm/s

(Note 4)



MR: Rolling Moment
MP: Pitching Moment
MY: Yawing Moment

■ Axis dimensions

[BE60G-ST-M***] 400-watt absolute motor specifications

Type	Without brake	BE60G-ST-M**N-20	BE60G-ST-M**N-30	BE60G-ST-M**N-40	BE60G-ST-M**N-50	BE60G-ST-M**N-60	BE60G-ST-M**N-70	BE60G-ST-M**N-80	BE60G-ST-M**N-90	BE60G-ST-M**N-A0	BE60G-ST-M**N-B0	BE60G-ST-M**N-C0	BE60G-ST-M**N-D0	BE60G-ST-M**N-E0	BE60G-ST-M**N-F0
	With brake	BE60G-ST-M**B-20	BE60G-ST-M**B-30	BE60G-ST-M**B-40	BE60G-ST-M**B-50	BE60G-ST-M**B-60	BE60G-ST-M**B-70	BE60G-ST-M**B-80	BE60G-ST-M**B-90	BE60G-ST-M**B-A0	BE60G-ST-M**B-B0	BE60G-ST-M**B-C0	BE60G-ST-M**B-D0	BE60G-ST-M**B-E0	BE60G-ST-M**B-F0
Stroke X (mm)		200	300	400	500	600	700	800	900	1000	1100	1200	1300	1400	1500
Overall Length L (mm)		617.4 (647.4)	717.4 (747.4)	817.4 (847.4)	917.4 (947.4)	1017.4 (1047.4)	1117.4 (1147.4)	1217.4 (1247.4)	1317.4 (1347.4)	1417.4 (1447.4)	1517.4 (1547.4)	1617.4 (1647.4)	1717.4 (1747.4)	1817.4 (1847.4)	1917.4 (1947.4)
K		5(5)	6(6)	7(7)	8(8)	9(9)	10(10)	11(11)	12(12)	13(13)	14(14)	15(15)	16(16)	17(17)	18(18)
Weight (kg)		24.0 (25.2)	26.8 (28.0)	29.5 (30.7)	32.3 (33.5)	35.0 (36.2)	37.8 (39.0)	40.5 (41.7)	43.3 (44.5)	46.0 (47.2)	48.8 (50.0)	51.5 (52.7)	54.3 (55.5)	57.0 (58.2)	59.8 (61.0)

Note: The value in parenthesis applies to the axis with a brake.
 The "***" portion of the type indicates the ball screw lead.
 (20 for the ball screw lead of 20 mm, 10 for the ball screw lead of 10 mm)

14

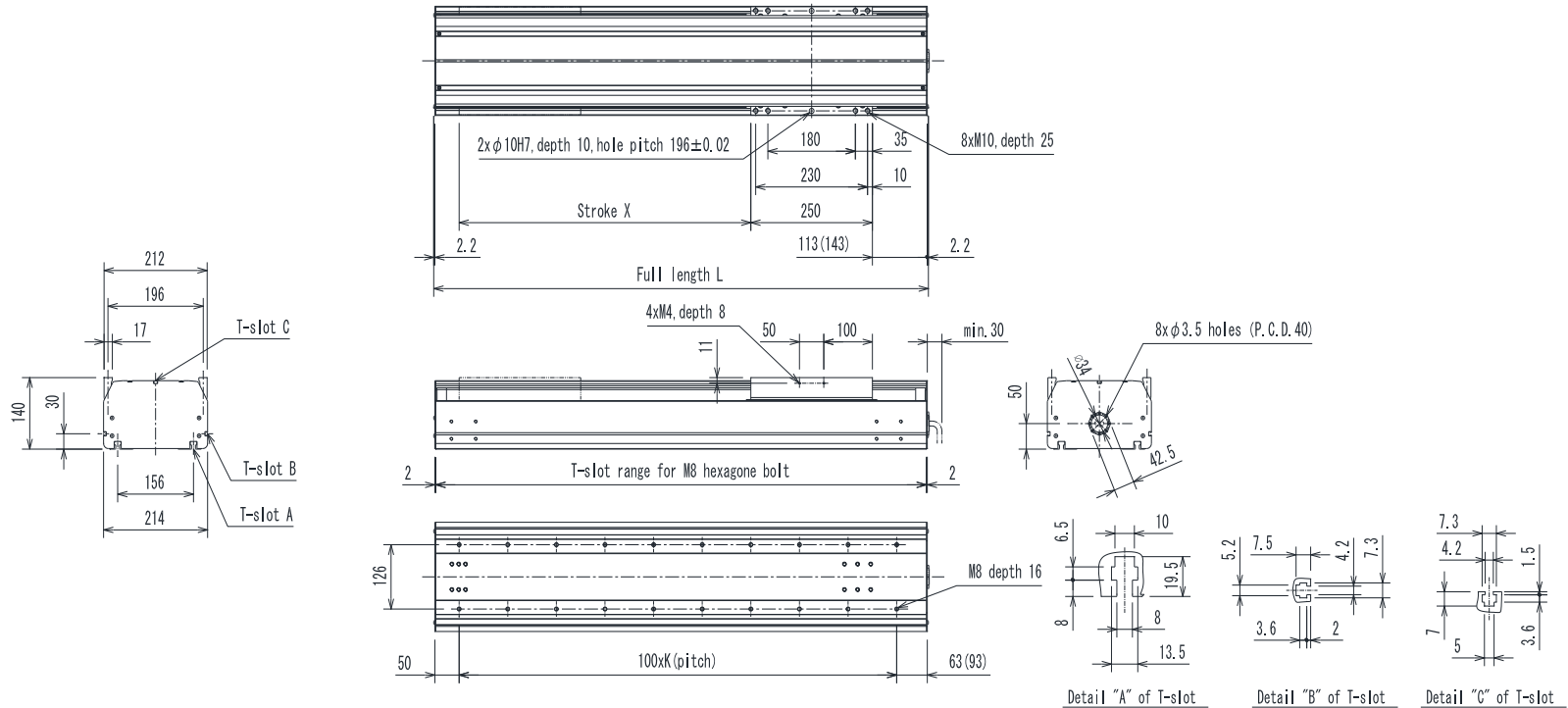

[BE60G-ST-L***] 400-watt absolute motor specifications

Type	Without brake	BE60G-ST-L**N-25	BE60G-ST-L**N-35	BE60G-ST-L**N-45	BE60G-ST-L**N-55	BE60G-ST-L**N-65	BE60G-ST-L**N-75	BE60G-ST-L**N-85	BE60G-ST-L**N-95	BE60G-ST-L**N-A5	BE60G-ST-L**N-B5	BE60G-ST-L**N-C5	BE60G-ST-L**N-D5	BE60G-ST-L**N-E5
	With brake	BE60G-ST-L**B-25	BE60G-ST-L**B-35	BE60G-ST-L**B-45	BE60G-ST-L**B-55	BE60G-ST-L**B-65	BE60G-ST-L**B-75	BE60G-ST-L**B-85	BE60G-ST-L**B-95	BE60G-ST-L**B-A5	BE60G-ST-L**B-B5	BE60G-ST-L**B-C5	BE60G-ST-L**B-D5	BE60G-ST-L**B-E5
Stroke X (mm)		150	250	350	450	550	650	750	850	950	1050	1150	1250	1350
Overall Length L (mm)		617.4 (647.4)	717.4 (747.4)	817.4 (847.4)	917.4 (947.4)	1017.4 (1047.4)	1117.4 (1147.4)	1217.4 (1247.4)	1317.4 (1347.4)	1417.4 (1447.4)	1517.4 (1547.4)	1617.4 (1647.4)	1717.4 (1747.4)	1817.4 (1847.4)
K		5(5)	6(6)	7(7)	8(8)	9(9)	10(10)	11(11)	12(12)	13(13)	14(14)	15(15)	16(16)	17(17)
Weight (kg)		25.5 (26.7)	28.3 (29.5)	31.0 (32.2)	33.8 (35.0)	36.5 (37.7)	39.3 (40.5)	42.0 (43.2)	44.8 (46.0)	47.5 (48.7)	50.3 (51.5)	53.0 (54.2)	55.8 (57.0)	58.5 (59.7)

Note: The value in parenthesis applies to the axis with a brake.
 The "***" portion of the type indicates the ball screw lead.
 (20 for the ball screw lead of 20 mm, 10 for the ball screw lead of 10 mm)

15

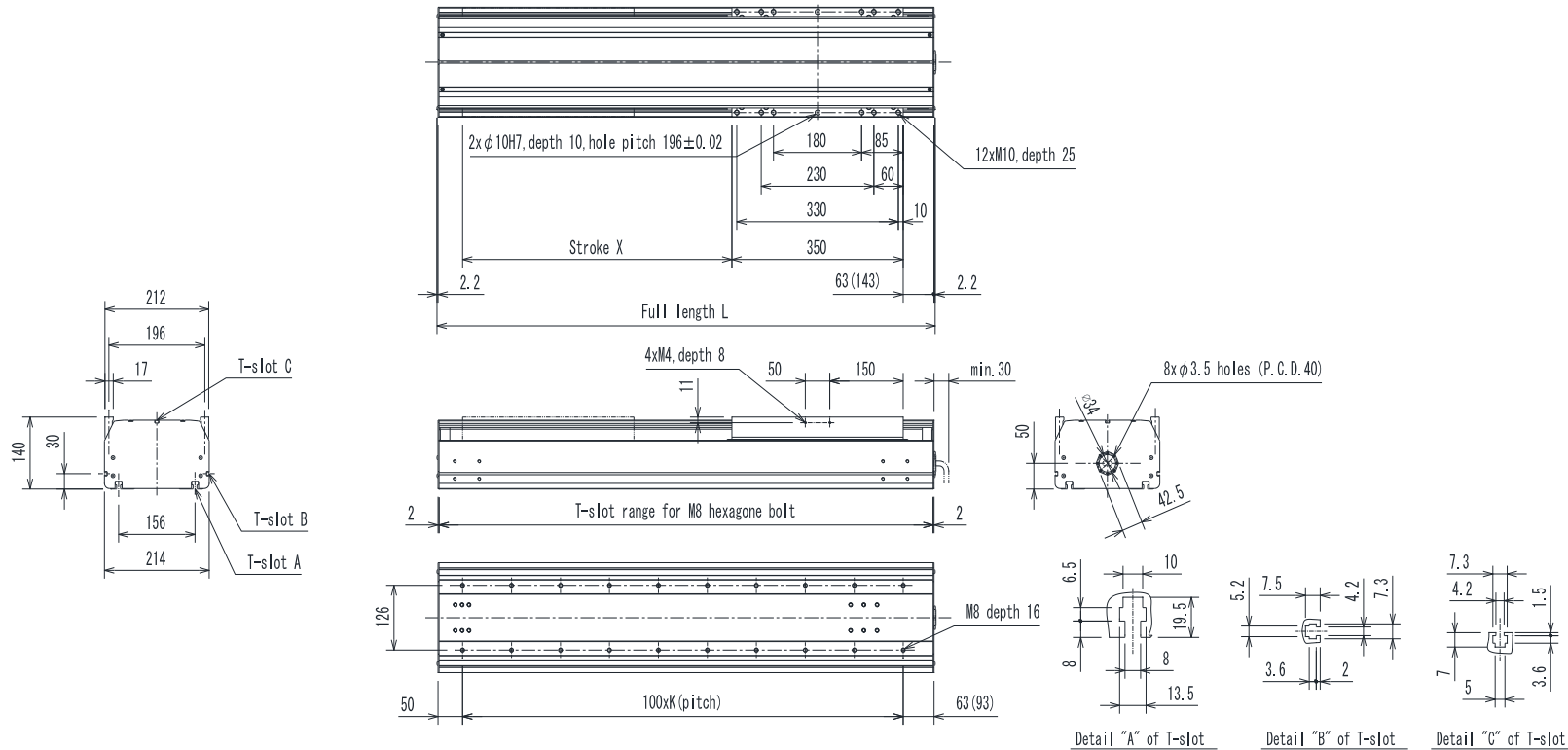

[BE60J-ST-M***] 750-watt absolute motor specifications

Type	Without brake	BE60J-ST-M**N-20	BE60J-ST-M**N-30	BE60J-ST-M**N-40	BE60J-ST-M**N-50	BE60J-ST-M**N-60	BE60J-ST-M**N-70	BE60J-ST-M**N-80	BE60J-ST-M**N-90	BE60J-ST-M**N-A0	BE60J-ST-M**N-B0	BE60J-ST-M**N-C0	BE60J-ST-M**N-D0	BE60J-ST-M**N-E0	BE60J-ST-M**N-F0	BE60J-ST-M**N-G0	BE60J-ST-M**N-H0
	With brake	BE60J-ST-M**B-20	BE60J-ST-M**B-30	BE60J-ST-M**B-40	BE60J-ST-M**B-50	BE60J-ST-M**B-60	BE60J-ST-M**B-70	BE60J-ST-M**B-80	BE60J-ST-M**B-90	BE60J-ST-M**B-A0	BE60J-ST-M**B-B0	BE60J-ST-M**B-C0	BE60J-ST-M**B-D0	BE60J-ST-M**B-E0	BE60J-ST-M**B-F0	BE60J-ST-M**B-G0	BE60J-ST-M**B-H0
Stroke X (mm)		200	300	400	500	600	700	800	900	1000	1100	1200	1300	1400	1500	1600	1700
Overall Length L (mm)		692.4 (727.4)	792.4 (827.4)	892.4 (927.4)	992.4 (1027.4)	1092.4 (1127.4)	1192.4 (1227.4)	1292.4 (1327.4)	1392.4 (1427.4)	1492.4 (1527.4)	1592.4 (1627.4)	1692.4 (1727.4)	1792.4 (1827.4)	1892.4 (1927.4)	1992.4 (2027.4)	2092.4 (2127.4)	2192.4 (2227.4)
K		5(5)	6(6)	7(7)	8(8)	9(9)	10(10)	11(11)	12(12)	13(13)	14(14)	15(15)	16(16)	17(17)	18(18)	19(19)	20(20)
Weight (kg)		37.2 (38.8)	39.9 (41.6)	42.7 (44.3)	45.4 (47.1)	48.2 (49.8)	50.9 (52.6)	53.7 (55.3)	56.4 (58.1)	59.2 (60.8)	61.9 (63.6)	64.7 (66.3)	67.4 (69.1)	70.2 (71.8)	72.9 (74.6)	75.7 (77.3)	78.4 (80.1)

Note: The value in parenthesis applies to the axis with a brake.
 The "***" portion of the type indicates the ball screw lead.
 (50 for the ball screw lead of 50 mm, 20 for the ball screw lead of 20 mm, 10 for the ball screw lead of 10 mm)

16

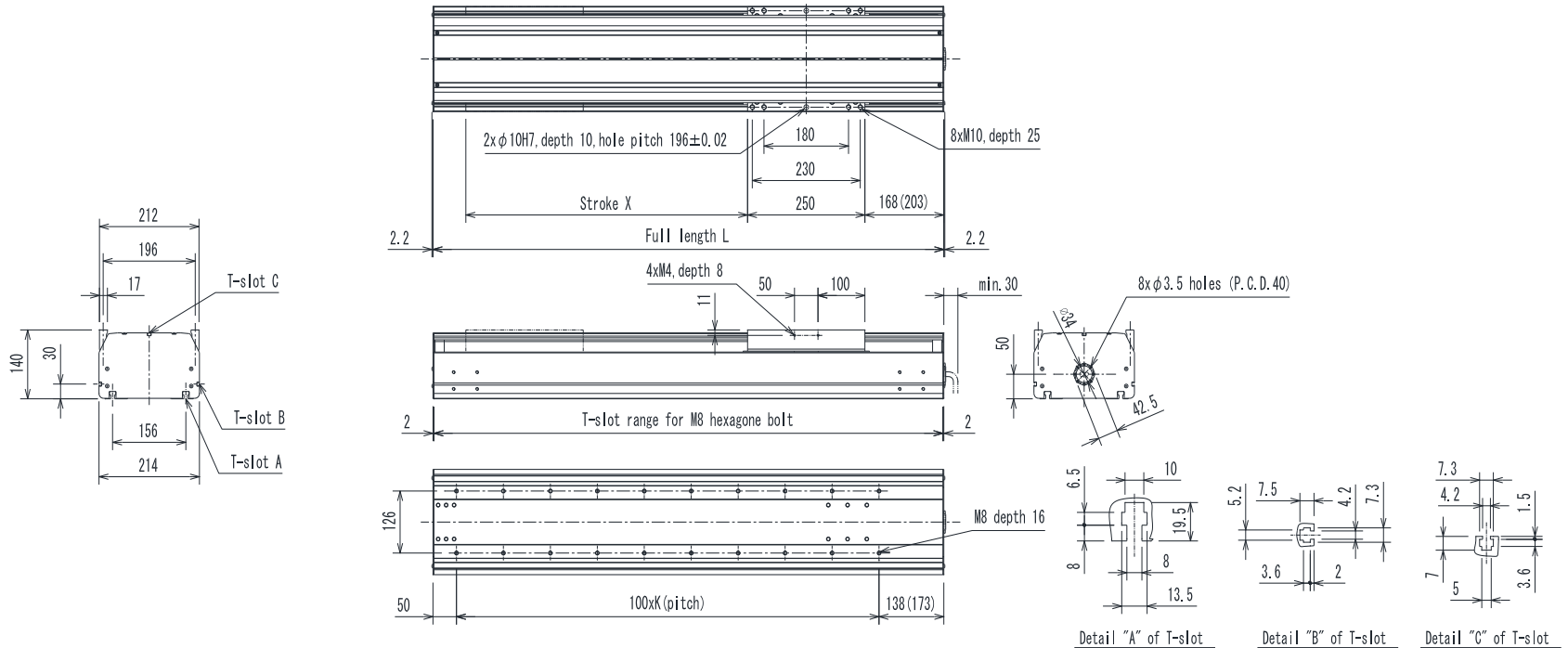

[BE60J-ST-L***] 750-watt absolute motor specifications

Type	Without brake	BE60J-ST-L**N-15	BE60J-ST-L**N-25	BE60J-ST-L**N-35	BE60J-ST-L**N-45	BE60J-ST-L**N-55	BE60J-ST-L**N-65	BE60J-ST-L**N-75	BE60J-ST-L**N-85	BE60J-ST-L**N-95	BE60J-ST-L**N-A5	BE60J-ST-L**N-B5	BE60J-ST-L**N-C5	BE60J-ST-L**N-D5	BE60J-ST-L**N-E5	BE60J-ST-L**N-F5	BE60J-ST-L**N-G5
	With brake	BE60J-ST-L**B-15	BE60J-ST-L**B-25	BE60J-ST-L**B-35	BE60J-ST-L**B-45	BE60J-ST-L**B-55	BE60J-ST-L**B-65	BE60J-ST-L**B-75	BE60J-ST-L**B-85	BE60J-ST-L**B-95	BE60J-ST-L**B-A5	BE60J-ST-L**B-B5	BE60J-ST-L**B-C5	BE60J-ST-L**B-D5	BE60J-ST-L**B-E5	BE60J-ST-L**B-F5	BE60J-ST-L**B-G5
Stroke X (mm)	150	250	350	450	550	650	750	850	950	1050	1150	1250	1350	1450	1550	1650	
Overall Length L (mm)	692.4 (727.4)	792.4 (827.4)	892.4 (927.4)	992.4 (1027.4)	1092.4 (1127.4)	1192.4 (1227.4)	1292.4 (1327.4)	1392.4 (1427.4)	1492.4 (1527.4)	1592.4 (1627.4)	1692.4 (1727.4)	1792.4 (1827.4)	1892.4 (1927.4)	1992.4 (2027.4)	2092.4 (2127.4)	2192.4 (2227.4)	
K	5(5)	6(6)	7(7)	8(8)	9(9)	10(10)	11(11)	12(12)	13(13)	14(14)	15(15)	16(16)	17(17)	18(18)	19(19)	20(20)	
Weight (kg)	38.7 (40.3)	41.4 (43.1)	44.2 (45.8)	46.9 (48.6)	49.7 (51.3)	52.4 (54.1)	55.2 (56.8)	57.9 (59.6)	60.7 (62.3)	63.4 (65.1)	66.2 (67.8)	68.9 (70.6)	71.7 (73.3)	74.4 (76.1)	77.2 (78.8)	79.9 (81.6)	

Note: The value in parenthesis applies to the axis with a brake.
 The "***" portion of the type indicates the ball screw lead.
 (50 for the ball screw lead of 50 mm, 20 for the ball screw lead of 20 mm, 10 for the ball screw lead of 10 mm)

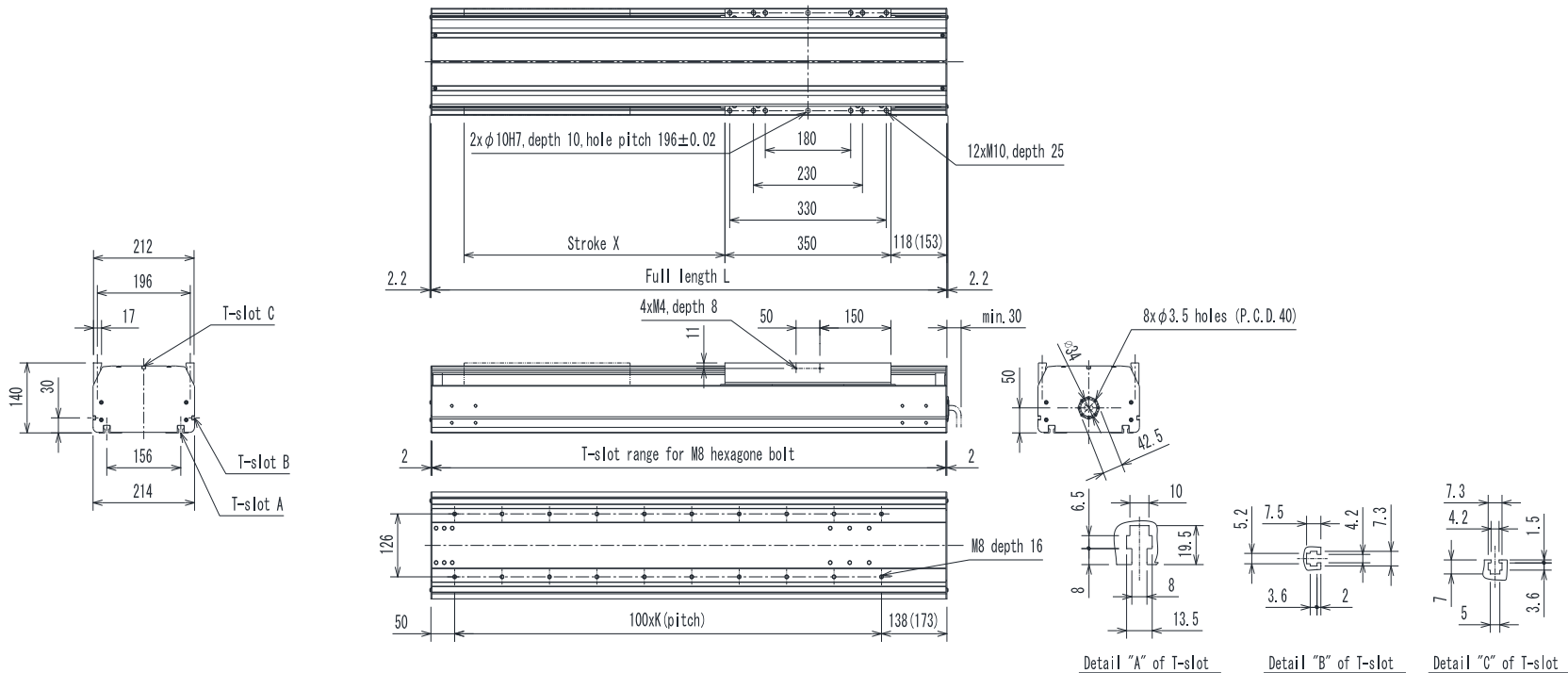

Chapter 4 Installing Actuator (Axis)

- This chapter describes the basic installation procedures for the axis and peripheral equipment.
- Installation shall comply with the instructions of this Chapter. If the installation procedure is incorrect, robot performance cannot be achieved. Not only that, the service life may be seriously reduced.



CAUTION Precautions for installation

● Environment of installation site

(1) The ambient environment for operation shall comply with the following requirements:

- Ambient temperature Working temperature: 0°C to 40°C
 Transportation and storage temperature: -10°C to 50°C
- Relative humidity: 30 to 90%RH without dew condensation
- Altitude: 1000 m or less
- Vibration 0.98 m/s² or less
- Dust: Free from conductive dust or dirt
- Gas: Free from flammable or corrosive gas
- Magnetic field: Free from a nearby device that may generate magnetic field
- Radiation: Not in the radiation controlled area
- Others: Without greasy fume

(2) This product is not designed as an explosion proof structure. Do not use it in a dusty place. Further, take sufficient care of the environment since it is not explosion-proof.

(3) Do not use it in a place with an organic solvent or white kerosene..
Of guide or ball screw grease is melted. It may cause malfunction.

● Precautions in installation

(1) Do not allow the product to fall down or be collided with other object during the transportation.

(2) Install the product where maintenance and inspection are easier.

(3) Install the controller within the range where it can be reached from the robot proper by a standard cable.

(4) Installation

- Install the product on a horizontal installation base.
- The installation base shall have the length that allows only the frame portion to be mounted.
- The installation base shall be made of a steel plate having a thickness of 20 mm or more where the plate has a machined surface with flatness of 0.2 or less. Install this product on this base to correct the bend and twist of the axis frame and to reinforce the axis frame.
- Install the oval bolts (installation bolts) of the axis at a pitch of approximately 150 mm.

■ 4.1 Installing Actuator (Axis)

Installation shall comply with the following procedures:

(1) Setting the oval bolt

From the axis end face, insert the oval bolt in the T-groove of the frame installation surface.

(2) Mounting on the installation base

Drill installation holes on the installation base of the carriage at a pitch of approximately 150 mm, and mount the product with oval bolts.

CAUTION

- The T-grooves (for M4 nut) on the side and top of the frame are used to install the CN box and optical parts. Never use these T-grooves to mount the axis.
- The nut tightening torque shall be 12 N-m.

■ 4.2 Robot type for each Axis

The robot type is indicated by the 6-digit numerals specified for each robot type.

If this setting is made, various parameter values suited to the axis to be used can be automatically set. The input procedure is given in Section 4.2 of the CA25 Instruction Manual (Basic Part).

- When used as a slider traveling type axis (in normal use)

	Ball screw Lead (mm)	Axis type	Robot type
BE60G (400W)	20	BE60G-ST-□20□-□□	603520
	10	BE60G-ST-□10□-□□	603540
BE60J (750W)	50	BE60J-ST-□50□-□□	605080
	20	BE60J-ST-□20□-□□	605020
	10	BE60J-ST-□10□-□□	605040



- When you have used the origin change sensor (optional) and set the home position to the side reverse to the normal side, input the robot type prior to change. After that, change the "Setting the motor rotating direction" in paragraph 2 of Section 13.4.5 described in the CA25 Instruction Manual (Basic Part) (Change it from 1 to 0).

■4.3 Parameter values

The parameters of this product are available in two types -- parameter 1 and parameter 2 -- depending on the frequency of use. The relationship between each parameter and the robot type is illustrated below:

Setting the robot type allows the parameters on the circled portion on the left to be automatically changed.

■4.3.1 Values of parameter 1 for each robot type

This parameter has a higher frequency of use.

- Straight axis (slider movable type)

Automatic setting	Robot type		603520	603540	605080	605020	605040
			(Lead 20)	(Lead 10)	(Lead 50)	(Lead 20)	(Lead 10)
	Software limit value (upper limit)		0000.00	0000.00	0000.00	0000.00	0000.00
	Software limit value (lower limit)		0000.00	0000.00	0000.00	0000.00	0000.00
○	Servo gain Position/Speed	P (position)	22	22	12	12	12
		V (speed)	55	55	75	60	30
	Pass area		0200				
	Origin offset value		0000.00	0000.00	0000.00	0000.00	0000.00
	Sequence of Return to Origin		1 (Note)	1 (Note)	1 (Note)	1 (Note)	1 (Note)
	JOG speed	L(Low speed)	010.0	010.0	010.0	010.0	010.0
		H(High speed)	050.0	050.0	050.0	050.0	050.0
	JOG inching movement		0.01	0.01	0.01	0.01	0.01

(Note) The Sequence of Return to Origin varies according to the combination format, installation conditions and others.

The customer is requested to set it in conformity to your operation conditions.

The initial value is common at "1" for all robot types. Thus, if there is no change, simultaneous origin return of all axes can be achieved.

■4.3.2 Values of parameter 2 for each robot type

• Straight axis (slider movable type)

Automatic setting	Parameter	Robot type					
		603520 (Lead 20)	603540 (Lead 10)	605080 (Lead 50)	605020 (Lead 20)	605040 (Lead 10)	
	Axis display	X	X	X	X	X	
	In position data value	00.05	00.05	00.05	00.05	00.05	
	Overflow data value	20000	20000	20000	20000	20000	
<input type="radio"/>	Feed forward data value	02000	02000	02000	02000	02000	
<input type="radio"/>	Direction of motor rotation	1	1	1	1	1	
<input type="radio"/>	Maximum speed	1200	600	2300	900	450	
<input type="radio"/>	Return to origin speed	(L) Low speed	002.0	002.0	002.0	002.0	002.0
		(M) Medium speed	020.0	020.0	020.0	020.0	020.0
		(H) High speed	100.0	100.0	100.0	100.0	100.0
<input type="radio"/>	Return to origin method	0	0	0	0	0	
<input type="radio"/>	Origin sensor logic	1	1	1	1	1	
	High speed return to origin position	0020.00	0020.00	0020.00	0020.00	0020.00	
<input type="radio"/>	Lead	20.000	10.000	50.000	20.000	10.000	
<input type="radio"/>	Encoder division number	32768	32768	32768	32768	32768	
<input type="radio"/>	Encoder pulse multiplier	4	4	4	4	4	
	Encoder type (Note)	a	a	a	a	a	
	Task and axis combination	[1] [0] [0] [0]					
	Task order of priority	[1] [1] [1] [1]					
	Task coordinate table	999	999	999	999		
	Task step number	5000	0000	0000	0000		

(Note) The encoder type cannot be set in this robot type since setting for each axis is not available.
See Section 13.4.17 of the CA25 Instruction Manual (Basic Part).

Chapter 5 Maintenance

■ 5.1 Precautions for inspection and maintenance work

(1) Precautions for inspection and maintenance work

Observe the following instructions at the time of inspection and maintenance:

1. The robot shall be inspected and maintained by the personnel having a sufficient level of skill and experience.
If such personnel are not available, contact the manufacturer and request implementation of the relevant work or education of the person in charge.
2. Use adequate illumination.
3. The start switch of the stationary operation panel or some other similar portion shall be provided with a notice board to indicate that the inspection and maintenance work is currently in progress.
Before entering the fence and enclosure, lock the open power switch to turn off power completely. If the access of the fence or enclosure is provided with a safety plug, be sure to carry the related plug with you.
4. If you have to enter the fence and enclosure for inspection and inspection of the control circuit, turn off the drive power source.
5. If you have to operate the industrial robot in the inspection and maintenance work within the guard fence and enclosure, you are recommended to take the following measures:
 - Two persons should be engaged in the work in cooperation with each other. This means that role assignment should be made in such a way that one person supervises the work of the other person during the work.
 - It is required to select such a speed that contact with the robot can be avoided in the event of a possible operation error of the robot. Determine the speed suited for the relevant work.
 - Take care of the robot operation during the work. Press the emergency stop button immediately when an unexpected operation has been detected.
6. Before starting disassembly of the pressure gauge or replacement of the parts, release the residual pressure of the cylinder.
7. Before starting disassembly of the hydraulic and pneumatic systems or replacement of parts, take a sufficient care to avoid deposition or mixture of foreign substances such as dust.

(2) Action to be taken subsequent to inspection and maintenance work

1. After termination of the inspection or maintenance work, the inspection or maintenance worker shall carry the tools back to the original position.
2. After termination of the maintenance work, be sure to perform a test run to verify the result. The test run shall be performed from outside the fence and enclosure in principle.
3. After action of item 2 has been taken, the inspection or maintenance worker shall report termination of the inspection or maintenance work to his superior.

■ 5.2 Inspection before starting the work

- (1) Before starting your work with the robot, make sure of the following:
 1. Brake device function
 2. Emergency stop device function
 3. Contact preventive equipment and robot interlock function
 4. Related devices/robot interlocking function
 5. Possible damage of the external wiring and piping
 6. Error of supply voltage and hydraulic and pneumatic pressures
 7. Operation error
 8. Abnormal noise and vibration
 9. Contact preventive equipment state

- (2) This inspection shall be conducted outside the movable range wherever possible.

■ 5.3 Periodic inspection

Giving consideration to the robot installation site, frequency of use and durability of the parts, determine the inspection standards including the inspection item, inspection procedure, evaluation criteria and implementation period for the following items. Start inspection in conformity to these standards.

1. Looseness of major parts
2. Lubrication and other possible errors of the movable parts
3. Power transmission component trouble
4. Hydraulic and pneumatic system error
5. Electric system error
6. Operation failure detecting function error
7. Encoder error
8. Servo system error

■ 5.4 Greasing

(1) Greasing positions

The linear guide and ball screw of this product are provided with an oilless seal. To prevent a possible accident, check for the greasing conditions and damages on a periodic basis. If insufficient lubrication has been found out, supply grease according to the following steps. If any trouble such as a breakdown has been detected and repair work is required, contact the Service Divisions shown at the end of this Manual, and request repair to be made.

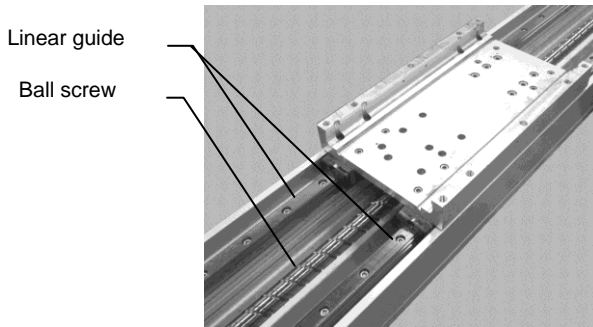

Greasing position	Type of grease (manufacturer)	Inspection and greasing intervals	Volume of grease
Ball screw	Albania Grease S2 (Shell)	Every 6 months	A thin layer of grease applied on the ball screw shaft
Linear guide			A thin layer of grease applied on the linear guide rail

(2) Inspection and greasing steps

1. Turn off the power and remove the power plug.
2. Remove the frame cover of the axis.
3. Inspect the linear guide and ball screw. If insufficient greasing has been found out, supply grease to the above-mentioned greasing positions.
4. Slowly move the slider manually or in the jog mode (at a speed of about 50 mm per second or less) five or more reciprocations and make sure that grease has been supplied into the ball nut and linear guide block.
5. Wipe off the overfilled or discolored grease.
6. Mount the frame cover again.

■ 5.5 Cleaning

Clean the robot proper.

Clean the robot proper in conformity to the following steps:

1. Turn off the power switch and remove the power plug.
2. Use waste cloth or such to remove the dust and dirt from the frame and covers etc.
3. Remove the frame cover and clean the dust and dirt from the frame cover. After removing it, supply grease according to the greasing step
4. Mount the frame cover back.

■ 5.6 Motor replacement procedure

Replace the motor according to the following steps:

- (1) Remove the frame cover and end plate.

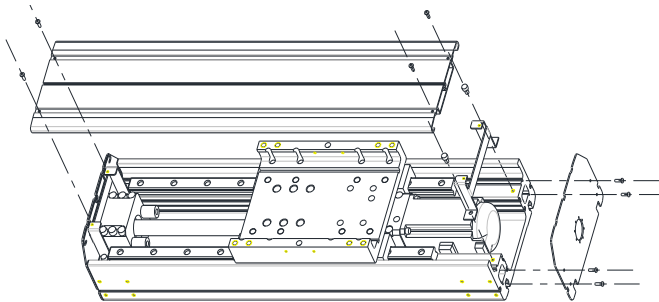

- Turn OFF power before starting the work.

- (2) Loosen the bolt on motor output shaft side of the coupling. (Do not loosen the bolt on the ball screw side).

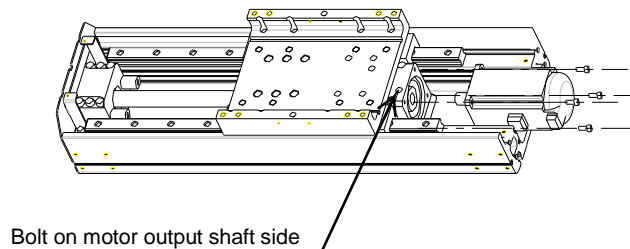

- (3) Remove the motor from the axis.
- (4) Mount a new motor on the same position. (Mount it so that the motor lead wire will be located on the top side). (Do not tighten the coupling fixing bolt in this stage.)
- (5) Connect the axis and controller on a temporary basis.
- (6) Connect the teaching pendant to the controller and return the axis to the origin.

CAUTION Before starting the return to the origin, set the servo gains to "0" for both the position and speed. For the setting procedures, see Sections 13.3.3 and 13.3.4 of the CA25 Instruction Manual (Basic Part).

- (7) The motor rotates. Taking care not to touch the rotating part, move the slider close to the origin. If the origin sensor has detected the slider, the motor starts the stop operation at the time of return to the origin
- (8) After the motor has stopped (after return to the origin), move the slider so that the distance between the motor will be "C". ("C" is the value described in Section 5.7 (Origin position adjustment).) After turning off the controller power, tighten the coupling fixing bolt. (The tightening torque BE60G(M4 bolt):3.4 N·m , BE60J(M5 bolt):7.0N·m.)

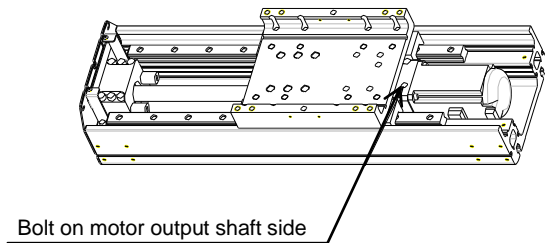

CAUTION Before tightening the coupling fixing bolt, be sure to turn OFF the controller power.

- (9) Turn ON the power again, and set the servo gain back to the original level. After that, make sure of the return to origin. After that, turn OFF power and remove the controller cable.
- (10) Mount the frame cover, end cover and end plate on the axis.

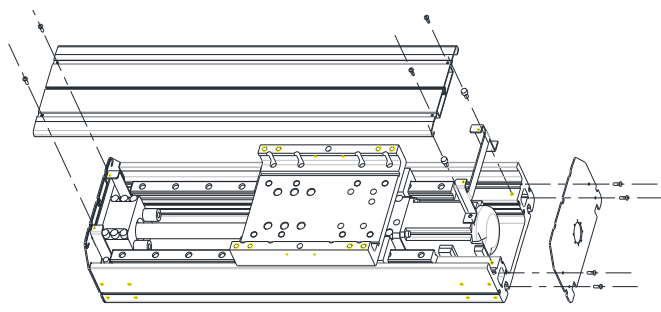

■ 5.7 Origin position adjustment

Adjust the origin according to the following procedure:

- (1) When the origin sensor is ON (Note), slider positions shall have the following relationship at the origin.

	Sensor installation reference position	Origin sensor ON position (Note)	Reference origin position
Applicable axis	A	B	C
BE60G-ST-M**N	275 mm	116 mm	111 mm
BE60G-ST-L**N	275 mm	66 mm	61 mm
BE60G-ST-M**B	305 mm	146 mm	141 mm
BE60G-ST-L**B	305 mm	96 mm	91 mm
BE60J -ST-M * *N	334mm	171mm	166mm
BE60J-ST-L * *N	334mm	121mm	116mm
BE60J-ST-M * *B	369mm	206mm	201mm
BE60J-ST-L * *B	369mm	156mm	151mm

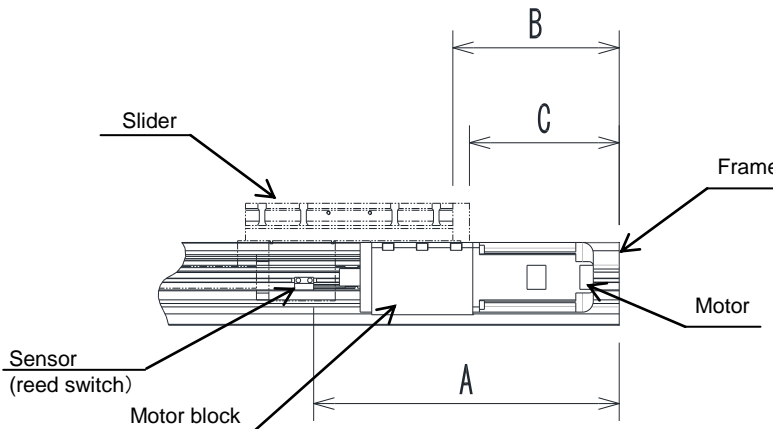

(Note) A reed switch of B-contact specifications is used as the origin sensor. Accordingly, the state is OFF in electrical terms. In this Manual, however, this is represented as "ON" for the sake of easier understanding.

The negative overrun position (-) indicates the position where the slider has hit the motor block damper and cannot move toward the motor any further. Normally, the position about 5 mm shifted toward the motor from the reference origin is the negative overrun position.

CAUTION

The origin sensor must be turned "ON" even if the slider is located at the negative overrun position.

When the sensor has been turned OFF at the negative overrun position, the return to origin will be disabled from this position.

- (2) The origin is found in either one of two ends of the axis. It should be noted that, when the tip end of the axis is assumed as the origin, the origin change sensor (optional) must be used.

If the origin must be changed close to the center of the stroke for the convenience of the customer, be sure to provide a stopper at the overrun dimension of about 5 mm from the origin stop position.

The distance from the origin sensor ON position to the origin stop position should be set at 5 mm (for a ball screw lead of 10 mm or 20 mm) and 3 mm (for a ball screw lead of 5 mm).

[Slide position checking procedure when origin sensor is turned ON]

- Turn OFF the controller power, and move the slider 50 to 100 mm from the origin. After that, turn ON the power and return the axis to the origin. (In case of the axis with a brake, turn ON the power. After that, use the jog mode for this operation.)
- The origin sensor ON position is where the slider speed changes (from intermediate to low speed) during return to the origin.

In this case, the slider does not stop until the return to origin is completed (detection of Z phase). (It does not stop at the origin sensor ON position.)

- When it must be stopped at the origin sensor ON position and accurate verification is necessary, take the following steps:

1. Change the origin return system from the Z-phase detection system to the sensor detection system. For this change, use the teaching pendant to change "7 Origin return system" in parameter 2 from 0 to 1. (See Section 13.4.11 of the CA25 Instruction Manual (Basic Part).)
2. Turn OFF the controller power and move the slider 50 to 100 mm from the origin. Then turn on the power and return the axis to the origin. (When the axis is provided with a brake, use the jog mode to perform this step after turning on the power.)
3. The origin sensor ON position is where the slider has stopped after completion of return to the origin. (In the sensor detection system, the origin is where the sensor has turned on.)



After verification, be sure to reset the origin return system back to the Z-phase detection system.

- Only for the axis without brake, the origin sensor ON position can be verified by the following method in addition to the above-mentioned method.

1. Connect the teaching pendant and set the servo free. After that, display the origin sensor monitor screen.
2. Slowly move the axis slider manually to the origin return position from close to the center of the stroke. Find the position where the origin sensor of the monitor screen of the teaching pendant is turned on. (See Section 14.2 of the CA25 Instruction Manual (Basic Part).)

[Movement of origin sensor]

- Compare the slider origin sensor ON position with the dimension B of Section 5.7. Move the origin sensor position by the difference in dimension.

■ 5.8 Replacement of ball screw

- If the replacement of ball screw needs to be replaced, contact our sales office closest to your company. It must not be replaced by the customer.
- This replacement is performed for each axis. It should be noted that this replacement cannot be made inside the device or in the combined state.

■ 5.9 Replacement of linear guide

- Replace the linear guide in the same procedure as the ball screw. Contact our sales office.

Chapter 6 Spare Parts

■6.1 Maintenance

When a trouble has occurred to the robot proper and you have found it out at an earlier stage, you cannot repair it if you have no repair parts. Accordingly, you are recommended to keep spare parts on hand.

No.	Parts name	Remarks
1	AC servo motor (encoder: absolute)	For straight axis (400W)
2	AC servo motor with brake (encoder: absolute)	For straight axis with brake (400 W)

TOSHIBA MACHINE CO.,LTD. HEAD OFFICE

Electronic Equipment Sales Group, Control Systems Division
2068-3, Ooka, Numazu-shi, Shizuoka-ken 410-8510, Japan
TEL: [81]-(0)55-926-5032 FAX: [81]-(0)55-925-6527

TM ROBOTICS (AMERICAS) INC.

755 Greenleaf Avenue, EIK Grove Village, IL 60007, U.S.A.
TEL:[1]-847-593-1616 FAX:[1]-847-593-0897

TOSHIBA MACHINE (THAILAND)CO.,LTD.

127/28 Panjathanee Tower, 23th Floor, Nothree Road, Khwaeng
Chong Nonthree, Khet Yannawa, Bangkok 10120, THAILAND
TEL: [66]-(0)2-681-0158 FAX: [66]-(0)2-681-0162

TM ROBOTICS(EUROPE) LTD.

Unit 2, Bridge Gate Centre,
Martinfield, Welwyn Garden City, Herts AL7 1JG UK
TEL: [44]-(0)1707-290370 FAX: [44]-(0)1707-376662

URL: <http://www.toshiba-machine.co.jp/seiji/prod/sr>

<http://www.tmrobotics.com>

<http://www.tmrobotics.co.uk>