

TOSHIBA MACHINE

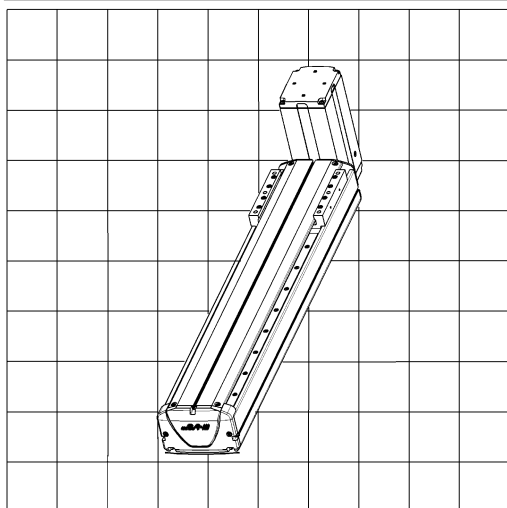

ROI BOT
BA-III SERIES

MODEL : BE30
Belt-Driven Actuator

ACTUATOR INSTRUCTION MANUAL

TOSHIBA MACHINE CO., LTD.

Keep this manual nearby for future reference.

Introduction

Before using the ROIBOT BA-III series, read through and completely understand this instruction manual to assure correct use.

For general information for the ROIBOT Arm BA-III Series, refer to CA25 Instruction Manual (Basic Part).

CAUTION

1. The contents of this manual are subject to change without prior notice.
2. The contents of this manual are subject to change without prior notice to effect improvements.
3. All efforts have been made to assure the contents of this manual. If you have any questions, or find any mistakes, however, please contact Toshiba Machine.
4. Toshiba Machine will not be held responsible for any effects caused by using this equipment, regardless of Item 3 above.
5. This equipment does not have an explosion-proof structure. Take utmost care of the operating environment.

Contents

- Chapter 1 Safety..... 1
 - 1.1 Cautions for safety 1
 - 1.2 For your safe operation 5
 - 1.3 Warranty 8
- Chapter 2 Shipment List..... 10
- Chapter 3 Axis Specifications 11
 - 3.1 Axis type and names of individual parts 11
 - 3.2 Single axis specification 12
- Chapter 4 Cable Installation 17
- Chapter 5 Installing Actuator (Axis) 18
 - 5.1 Installing Actuator (Axis) 19
 - 5.2 Robot type for each Axis..... 19
 - 5.3 Parameter values 20
- Chapter 6 Precautions for Use..... 22
 - 6.1 Fluctuation in sliding resistance during long-term storage..... 22
 - 6.2 In the event of collision..... 22
- Chapter 7 Maintenance 23
 - 7.1 Precautions for inspection and maintenance work 23
 - 7.2 Inspection before starting the work 24
 - 7.3 Periodic inspection..... 24
 - 7.4 Cleaning 25
 - 7.5 Timing belt and motor replacement procedure..... 25
 - 7.6 Routing the timing belt 29
 - 7.7 Origin position adjustment..... 32
 - 7.8 Linear guide replacement..... 32
 - 7.9 Greasing 33
- Chapter 8 Spare Parts..... 34

Overview

- This manual describes the axis type expression method, specifications and motor replacement procedures, etc., according to the type of axis.
- For the installation, see the instruction manual (installation of actuator) provided separately.

Chapter 1 Safety

■ 1.1 Cautions for safety

- Before the installation, programming, operation, maintenance and inspection of the equipment, be sure to read through this manual so that you can use the ROIBOT with safety.
- After you have read this manual, keep it nearby for future reference.

Be sure to observe the instructions for ensuring operation safety of the ROIBOT.

This manual contain the important information to prevent injury to the operators and persons nearby, to prevent damage to assets and to assure correct use of the equipment.

Make sure that you have well understood the following details (indications and symbols) before reading this manual. Always observe the information that is noted.

 **WARNING** : If you have neglected this instruction and caused a handling error, death or serious injury may occur.

 **CAUTION** : If you have neglected this instruction and caused a handling error, human injury or property damage (damages to houses, household goods and domestic animals) may occur.

 **CAUTION** : This gives a brief description of the major points of operation procedures, precautions and method for effective use of the machine.

⚠ WARNING

- **Install the safety fences to prevent anyone from entering the working envelope of the robot.**
When the door is attached to the safety fence, the robot should be stopped at emergency at the same time that the door has opened.
- **Connect the EMERGENCY STOP pushbutton switch to the emergency stop input terminal of the controller and mount the same switch at an easy-to-operate place in an emergency.**
The EMERGENCY STOP switch must not be reset automatically and cannot be reset negligently by any person.
- **Wiring should be done safely and completely according to the Electrical Installations Technical Requirements and Interior Wiring Requirements of Japan.**
Incorrect wiring will result in an electric shock or a fire.
- **The equipment MUST NOT be repaired or modified without prior written permission from the manufacturer.**
Otherwise, an accident or damage will be caused.
- **Before the maintenance and inspection, be sure to turn off the controller main power switch. Take all necessary measures to prevent anyone other than the worker engaged in adjustment of the robot from negligently turning the power on. (Lock the switch and put a tag showing "DO NOT turn the power on.") Also, DO NOT touch the controller interior three (3) minutes after the power is turned off.**
Otherwise, you may get an electric shock due to residual voltage of the capacitor.
- **DO NOT touch the motor, heat sink and cement resistor in the controller.**
They are too hot and you may get burnt. Before performing inspection, take enough time to cool them off.
- **DO NOT pour water on the equipment interior or exterior, or drain water from it. Otherwise, you may get an electric shock, or the equipment will be damaged.**
When the equipment has contaminated, wipe it off with a hard squeezed cloth. DO NOT use a thinner, benzene or other organic solvent.
- **DO NOT throw away metals, combustibles or other contaminant into the opening of this equipment.**
A fire or an electric shock will be caused.
- **DO NOT put your finger or hand on the movable part or opening of the equipment.**
Otherwise, you may get injured.
- **When using the actuator in other than the horizontal state, select the vertical actuator.**
This actuator (belt-driven) cannot be used for the vertical application.

⚠ WARNING

- **As the equipment is heavy, make sure of its weight and gravity center position and disconnect the cables when carrying the equipment.**
Also, DO NOT carry the equipment with the slider. Otherwise, the slider will move and you will get injured.
- **DO NOT use this equipment for the living body as a massaging machine.**
Otherwise, you will be injured due to incorrect teaching or mis-operation.
- **This equipment has not a sealed structure. During use, grease or wear of the belt may scatter from the opening of the equipment.**
When using this equipment for food and chemical applications, take appropriate measures against entry of them.
- **Enter the robot type and initialize the memory correctly.**
Otherwise, the robot may move unexpectedly and you will be injured.
- **DO NOT use this equipment in an atmosphere of inflammable gas or an atmosphere inducing an explosion.**
As this equipment is not explosion-proof, it may explode in the worst occasion.
- **DO NOT damage, break, process, forcibly bend, stretch, place a heavy object on or pinch the cables (power cable, controller cable).**
Otherwise, an electric shock or a fire will be caused.
- **Should an abnormality such as smoke or nasty smell occur, turn the power off immediately and stop using the equipment.**
If the equipment is used continuously, an electric shock or a fire will be caused.

⚠ CAUTION

- **DO NOT place the equipment at a place where the ambient temperature exceeds 40°C, or where the temperature changes sharply, causing condensing, or where it is exposed to direct sunlight.**

Additionally, if the equipment is installed at a narrow place, the ambient temperature rises due to heat generation in the controller itself or external device, which will result in malfunction or mis-operation of the equipment.

- **DO NOT use the equipment at a place where an impact or vibration is involved. Also, DO NOT use the equipment in an atmosphere where conductive dust, corrosive gas or oil mist generates.**

Otherwise, a fire, electric shock, malfunction or mis-operation will be caused.

- **DO NOT use the equipment at a place where too much dust or dirt exists.**

If the equipment is used at such a place, it may malfunction because this equipment is not dust-proof.

- **DO NOT use repair parts other than those designated by the manufacturer.**

Otherwise, the equipment cannot be operated to its full capacity and will cause malfunction.

- **Mount the robot on a highly rigid frame.**

If rigidity of the frame is not enough, vibration (or resonance) may be caused during the robot operation, adversely affecting the operation.

■ 1.2 For your safe operation

When you use the ROIBOT BE Series, be sure to take the measures in conformity to the following instruction:

This machine is an industrial robot in conformance to the provisions of Paragraph 31 of Article 36 of the Ordinance on Industrial Safety and Hygiene. Necessary cautions are specified in the "Selection", "Installation", "Use", "Periodic Inspection, etc." and "Education" of the "Technical Guideline on Safety Standards for Use of Industrial Robot" conforming to the Article 28 of the Industrial Safety and Health Law. You are requested to read them carefully and to observe the instructions. The following introduces some of them.

■ 1.2.1 Safety measures

(1) A safety barrier shall be provided to ensure that any person cannot enter the working area of a robot.

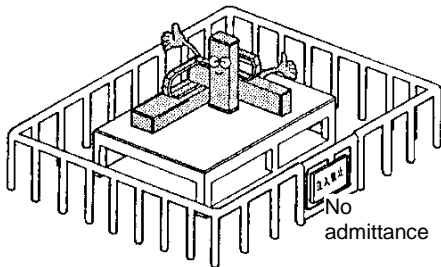

1. The barrier shall have sufficient strength to withstand the force generated during the work or environmental conditions. The barrier shall have such a structure that cannot be easily adjusted, removed or cleared.
2. The safety barrier shall be free from any serrated or sharp edge or protrusions.
3. The safety barrier shall be designed in a stationary structure.
4. When a safety barrier is equipped with a door, an interlock shall be provided so that the robot will be stopped by opening of the door.

(2) An emergency stop device shall be installed where the robot can be easily stopped by the operator immediately in the event of emergency.

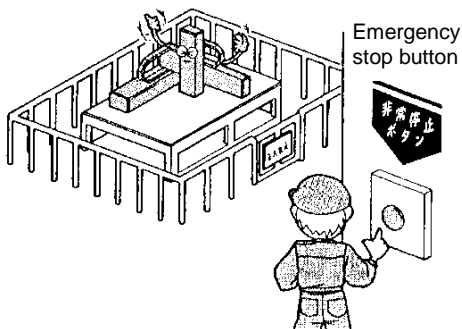

1. The emergency stop function shall ensure immediate and reliable stop of a robot when the emergency stop button switch has been operated by an operator.
2. The emergency stop button shall be red.
3. The emergency stop device shall be located so that it can be easily pulled, pressed or touched by the operator, and it can block a beam of light.
4. The emergency stop button shall be structured in such a way that it is not automatically reset after having been operated, and cannot be reset carelessly.

(3) For safety, never modify the robot main unit or control device.

■1.2.2 Precautions for installation

Observe the following instructions when installing a robot:

- (1) The robot shall be laid out to ensure the work space required for robot teaching, maintenance and inspection.
- (2) The robot controller, other controllers and stationary operation panel shall be installed outside the movable range and where the operator can watch the robot operations.
- (3) The pressure gauge, hydraulic pressure gauge and other instruments shall be installed in clearly visible positions.
- (4) The electric wiring and hydraulic/pneumatic piping shall be provided with protective covers if they may be damaged.
- (5) To ensure effective operation of the emergency stop device in the event of emergency, emergency stop device switches shall be installed on locations other than the operation panel, as required.

■1.2.3 Precautions for use

Observe the following instructions when using a robot:

[Work within the movable range]

- (1) Work provisions
 - Determine provisions for the following items and perform the work in conformity to them:
 1. Root operation methods and procedures required in the work such as startup method and switch handling method.
 2. Speed of robot main unit in teaching.
 3. Signaling method for work adjustment among more than one operator.
 4. Action to be taken by the operator for each problem.
 5. Procedures for confirming the release of the emergency and safety when restarting the robot operation after the robot operation has been stopped due to the operation of the emergency stop device.
 6. Measures to protect against the hazard due to unexpected operation of the robot described below (in addition to the above items), or the hazard caused by a robot operation error.
 - Indication on the operation panel.
 - Measures to ensure safety of the operator working within the movable range.
 - Working position and posture.
 - Prevention of operation error due to noise.
 - Signaling method for work adjustment with operators of related devices.
 - Error type and evaluation procedure.
 7. The work provisions shall meet the requirements of the robot type, installation site and work.
 8. The work provisions shall be prepared by consultation with the related operators, manufacturer's engineers and industrial safety consultant.
- (2) Indication on the operation panel
 - To ensure that the start switch and selector switch will not be carelessly operated by a person other than the personnel in charge of this work, the switch shall be provided with an easy-to-read indication to show that the work is in progress. Alternatively, the operation panel cover shall be provided with locking or other means.
- (3) Measures to ensure the operation safety of the personnel working within the movable range
 - Any one of the following measures or other measures on the equal or higher level shall be taken so that you can stop the robot operation immediately in the event of an error when working within the movable range:

1. An adequately authorized supervisor shall be assigned outside the movable range and where the robot operations can be observed. This supervisor shall be exclusively in charge of the supervision and shall be responsible for the following:
 - The supervisor shall cause the emergency stop device to be operated immediately in the event of an error.
 - The supervisor shall ensure that a person other than the personnel in charge of this work is kept outside the movable range.
2. The emergency stop device switch shall be placed under the control of the person working within the movable range.
3. A portable operation panel having a structure capable of on/off operation of the power source, oil hydraulic or pneumatic source shall be used in the work.
- (4) Inspection prior to start of the work such as teaching

Prior to start of the work such as teaching, the following items shall be inspected. If any error is detected, immediately repair the trouble or take other required action.

 1. Check if the covering or sheathing of the external power source is damaged or not. (This check must be made after the power has been turned off).
 2. Check if the operation of the robot proper is faulty.
 3. Check for the functions of the braking device and emergency stop device.
 4. Check if there is any leakage of air or oil from the piping.
- (5) Cleaning of working tools

When such working tools as a painting nozzle are mounted on the robot proper, and these working tools must be cleaned, it is preferred that these tools should be automatically cleaned so that the number of machines entering the movable range can be minimized.
- (6) Release of residual pressure

Before disassembling the pneumatic components or replacing their parts, release the residual pressure in the drive cylinder.
- (7) Operation check

Perform the verification operation without entering the movable range, wherever possible.
- (8) Illuminance

The illuminance required for operation safety shall be maintained.

[For automatic operation]

- (1) Action before startup

Before starting the robot, check for the following items in advance and determine a signaling method for work adjustment among related operators.

 1. Make sure that there is no person within the movable range.
 2. The movable operation panel and tools shall be located at specified positions.
 3. There shall be no error indication for the robot or related devices.
- (2) Action for automatic operation and in the event of an error
 1. Make sure that there is an indication to show that the automatic operation is now in progress, after the robot has been started.
 2. When a problem has occurred to the robot or related device and you have to enter the movable range to take emergency measures, stop the robot operation, for example, by operating the emergency stop device before entering the movable range. At the same time, carry a safety plug with you, and ensure that the start switch is provided with the indication to show that the work is now in progress. Take measures so that any other person than the operator in charge of the emergency measures cannot operate the robot.

Requesting your cooperation

For the safety instructions which seem especially important, relevant warning label is attached to the equipment.

When the label attached to the equipment has peeled off or the characters are defaced and unreadable, please procure it from our sales agent in your territory by specifying the part number, and attach it to the original place.

Warning label for actuator

Part number: 55620157

 WARNING	<ul style="list-style-type: none">• Before the installation, programming, operation, maintenance and inspection of the equipment, be sure to read through this manual so that you can use the ROIBOT with safety.• Install the safety fences to prevent anyone from entering the working envelope of the robot.• DO NOT put your finger or hand on the movable part or opening of the equipment. Otherwise, you may get injured.• When using the actuator in other than the horizontal state, be sure to select the actuator with brake. Otherwise, the slider will drop at power OFF, and you will be injured.
--	--

■ 1.3 Warranty

■ 1.3.1 Warranty period

This product is warranted for one of the following periods whichever comes first.

- (1) For 24 months after shipment from our factory.
- (2) For 18 months after installation at the customer's factory.
- (3) For 4000 hours of operation.

■ 1.3.2 Details of warranty

- (1) This product is warranted. The scope of the warrant includes the specifications and functions described in the Specification, catalog and Instruction Manual. We are not responsible for any secondary or incidental damages caused by the trouble of this product.
- (2) We will repair, on a free-of-charge basis, the trouble caused in the handling or use of the product within the warranty period of this product as described in the Instruction Manual attached to this product. Alternatively, such trouble will be repaired after the product has been returned to our factory. If the problem is solved by a dispatch of service personnel to meet the convenience of the customer, we may claim payment from your company regarding the transportation expenses, lodging expenses or other expenditures not directly related to the repair of the product.

■1.3.3 Exemption from responsibility

The following cases shall be excluded from the scope of warrant.

- (1) The trouble and damage caused by the use of the product according to a method not described in the Instruction Manual, or by a careless error in use.
- (2) Problems caused by chronological changes or wear by use (such as natural fading of paints, deterioration of the consumable parts ^{*1}).
- (3) Problems caused by sensory phenomena (e.g. generated noise without affecting the function).
- (4) Modification or disassembling not authorized by our company.
- (5) Troubles or damages caused by inadequate maintenance and inspection or improper repair.
- (6) Troubles or damages caused by natural disaster, fire and other external factors.
- (7) Internal data such as programs and points created or modified by the customer.
- (8) Problems caused when this product purchased in Japan is brought to an overseas country.

*1 : Consumable parts are defined as the parts maintenance replacement parts (spare parts) described in the Instruction Manual of each product, and the parts (e.g. backup battery) that must be replaced on a periodic basis.

■1.3.4 Precautions

- (1) When you have used the product beyond the specifications of the product, we cannot warrant the basic performances of the product.
- (2) Should you fail to observe the instructions given in "WARNING" and "CAUTION" described in the Instruction Manual, we are not responsible for any personal injury, damages or trouble that may occur.
- (3) Please note that the "WARNING" and "CAUTION" described in the Instruction Manual, and other descriptions are within the scope assumed by our company.
- (4) The numerical values given as technical data are theoretical values as a guideline showing the durability and others. They shall not be construed as indicating warranty. Note that these values are subject to change according to the conditions of use.

Chapter 2 Shipment List

When the axis proper is shipped, it is composed of the following parts:

- (1) Actuator(axis)
- (2) Number of oval bolts attached (M6×30)



- The above-mentioned axis-1 will be provided with the bolts in the number shown in the right-hand Table.

Axis stroke (mm)	Attached quantity
100~200	12
250~600	16
650~1000	20
1050~1300	26
1350~1850	32
2050~2600	40
2650~3200	48

- (3) Actuator Instruction Manual (this Manual)

Chapter 3 Axis Specifications

3.1 Axis type and names of individual parts

■ Type of axis

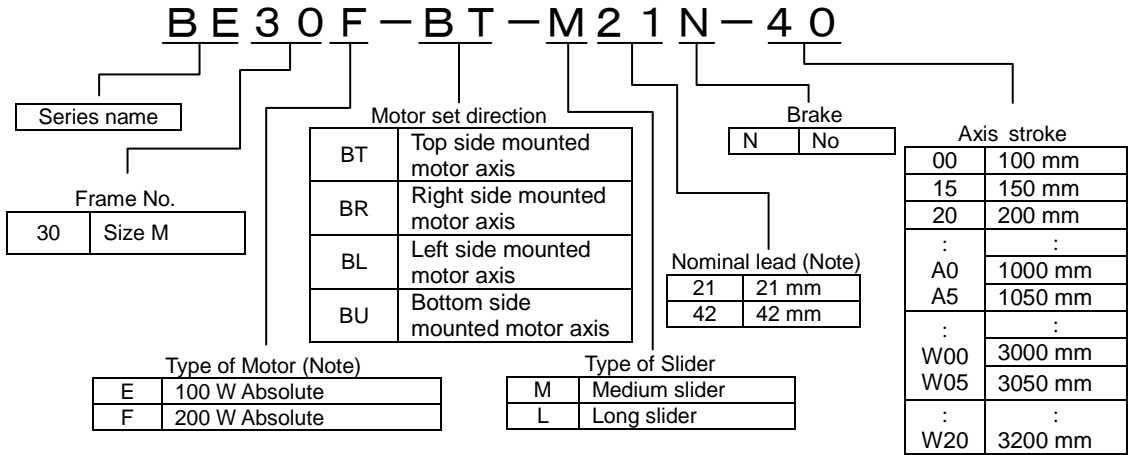

Note 1: Compatible only with the 21 mm-lead product in the case of a 100-watt motor

■ Names of individual parts

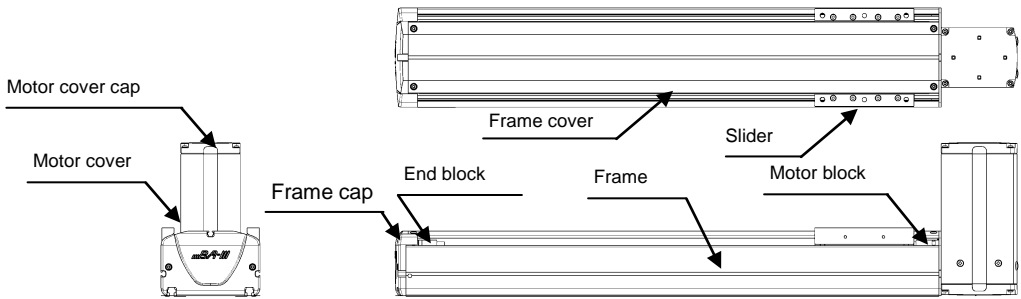

3.2 Single axis specification

Specifications

Type of axis BE30□-B□-□□□N-□□

The values enclosed in parentheses indicate those for the AC 200-watt servo motor.

Motor		AC 100-watt servo motor absolute) (AC 200-watt servo motor absolute)
Drive method		Timing belt Lead 21 mm Lead 42 mm
Guide method		Linear guide (Double) Bearing block ... 4 pieces
Maximum payload mass (Note 1)	Lead	Horizontal
	21 mm	15(40) kg
	42 mm (Note 2)	(20) kg
Maximum speed	Lead 21 mm	1000 mm/s
	Lead 42 mm	2000 mm/s
Static permissible moment (Note 3)	Medium slider	MR:510 N·m MP:430 N·m MY:370 N·m
	Long slider	MR:510 N·m MP:750 N·m MY:650 N·m
Repeated positioning accuracy		±0.04 mm
Resolution		0.01 mm
Rated thrust	Lead 21 mm	95(190) N
	Lead 42 mm	(95) N

(Note 1) This indicates the value when the acceleration/deceleration time is 0.3 s or more.
The part with a lead of 42 mm has an acceleration/deceleration time of 0.5 s or more.

(Note 2) The part with a lead of 42 mm is compatible only with a 200-watt motor.

CAUTION

Set the part with a lead of 21 mm to an acceleration/deceleration time below 0.3 s.
Set the part with a lead of 42 mm to an acceleration/deceleration time below 0.5 s.
A misalignment may occur in meshing between the timing belt and pulley

(Note 3)

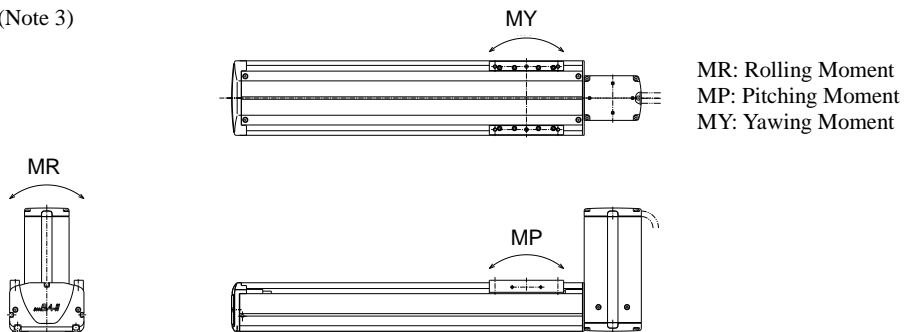

■ Axis dimensions

(1) Top side mounted motor axis [BE30*-BT-***N]

Type	10	20	30	40	50	60	70	80	90	A0	B0	C0	D0	E0	F0	G0	H0	J0	K0	L0	M0	N0	P0	Q0	R0	S0	T0	U0	V0	W00	W10	W20
Stroke X (mm)	100	200	300	400	500	600	700	800	900	1000	1100	1200	1300	1400	1500	1600	1700	1800	1900	2000	2100	2200	2300	2400	2500	2600	2700	2800	2900	3000	3100	3200
Weight (kg)	9.2	10.2	11.2	12.2	13.2	14.1	15.1	16.1	17.1	18.1	19.1	20.1	21.1	22.1	23.0	24.0	25.0	26.0	28.3	29.3	30.4	31.4	32.5	33.5	34.6	35.6	36.7	37.7	38.8	39.8	40.9	41.9
BE30E-BT-M21N-□□	10	20	30	40	50	60	70	80	90	A0	B0	C0	D0	E0	F0	G0	H0	J0	K0	L0	M0	N0	P0	Q0	R0	S0	T0	U0	V0	W00	W10	W20
BE30F-BT-M21N-□□	10	20	30	40	50	60	70	80	90	A0	B0	C0	D0	E0	F0	G0	H0	J0	K0	L0	M0	N0	P0	Q0	R0	S0	T0	U0	V0	W00	W10	W20
BE30F-BT-M42N-□□	10	20	30	40	50	60	70	80	90	A0	B0	C0	D0	E0	F0	G0	H0	J0	K0	L0	M0	N0	P0	Q0	R0	S0	T0	U0	V0	W00	W10	W20
Stroke X (mm)	150	250	350	450	550	650	750	850	950	1050	1150	1250	1350	1450	1550	1650	1750	1850	1950	2050	2150	2250	2350	2450	2550	2650	2750	2850	2950	3050	3150	
Weight (kg)	10.5	11.5	12.5	13.5	14.4	15.4	16.4	17.4	18.4	19.4	20.4	21.4	22.4	23.3	24.3	25.3	26.3	28.6	29.6	30.7	31.7	32.8	33.8	34.9	35.9	37.0	38.0	39.1	40.1	41.2	42.2	
BE30E-BT-M21N-□□	15	25	35	45	55	65	75	85	95	A5	B5	C5	D5	E5	F5	G5	H5	J5	K5	L5	M5	N5	P5	Q5	R5	S5	T5	U5	V5	W05	W15	
BE30F-BT-M21N-□□	15	25	35	45	55	65	75	85	95	A5	B5	C5	D5	E5	F5	G5	H5	J5	K5	L5	M5	N5	P5	Q5	R5	S5	T5	U5	V5	W05	W15	
BE30F-BT-M42N-□□	15	25	35	45	55	65	75	85	95	A5	B5	C5	D5	E5	F5	G5	H5	J5	K5	L5	M5	N5	P5	Q5	R5	S5	T5	U5	V5	W05	W15	
Stroke X (mm)	150	250	350	450	550	650	750	850	950	1050	1150	1250	1350	1450	1550	1650	1750	1850	1950	2050	2150	2250	2350	2450	2550	2650	2750	2850	2950	3050	3150	
Weight (kg)	11.1	12.1	13.1	14.1	15.0	16.0	17.0	18.0	19.0	20.0	21.0	22.0	23.0	23.9	24.9	25.9	26.9	29.2	30.2	31.2	32.3	33.4	34.4	35.5	36.5	37.6	38.6	39.7	40.7	41.8	42.8	

[NOTE] The format of the table lists only the end of the symbol "□□" part of the type. In the case of more than stroke 3000mm, it will be a three-digit code.
The values in parentheses are applicable when the stroke is 1850mm or over.

13

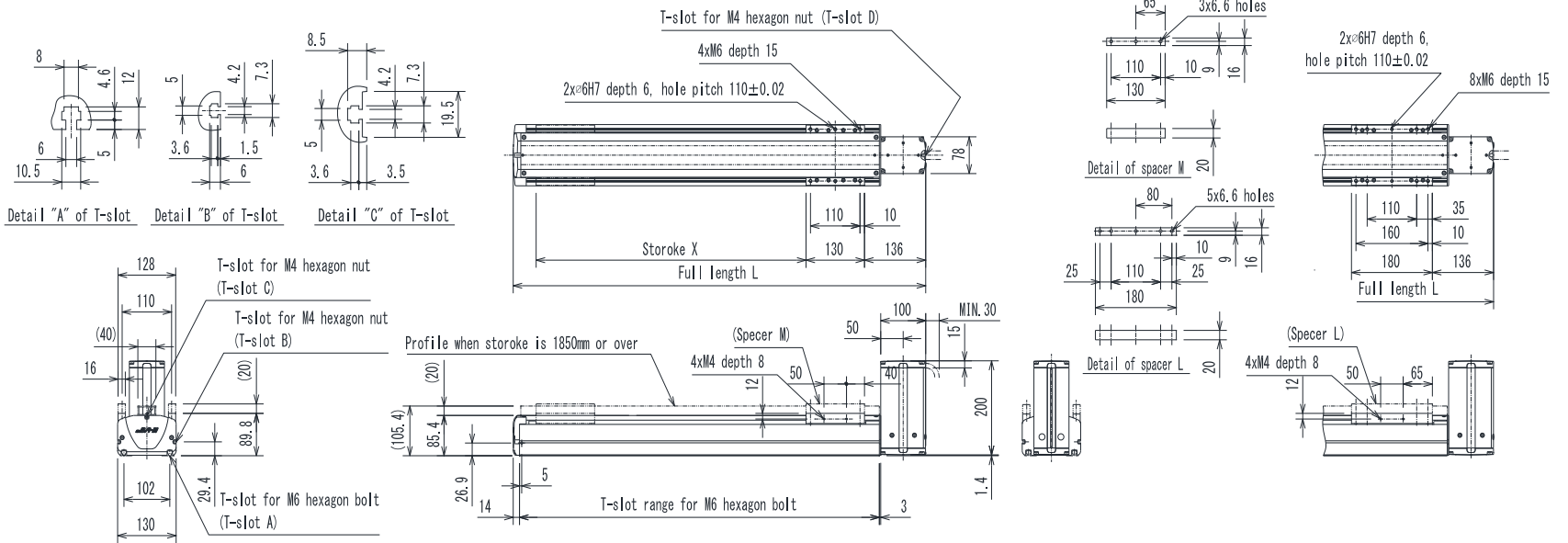

[BE30*-BT-M**N]

[BE30*-BT-L**N]

(2) Bottom side mounted motor axis [BE30*-BU-***N]

Type	Type																																
BE30E-BU-M21N-□□	10	20	30	40	50	60	70	80	90	A0	B0	C0	D0	E0	F0	G0	H0	J0	K0	L0	M0	N0	P0	Q0	R0	S0	T0	U0	V0	W00	W10	W20	
BE30F-BU-M21N-□□	100	200	300	400	500	600	700	800	900	1000	1100	1200	1300	1400	1500	1600	1700	1800	1900	2000	2100	2200	2300	2400	2500	2600	2700	2800	2900	3000	3100	3200	
BE30F-BU-M42N-□□	417	517	617	717	817	917	1017	1117	1217	1317	1417	1517	1617	1717	1817	1917	2017	2117	2217	2317	2417	2517	2617	2717	2817	2917	3017	3117	3217	3317	3417	3517	
Weight (kg)	BE30E Lead 21	9.2	10.2	11.2	12.2	13.2	14.1	15.1	16.1	17.1	18.1	19.1	20.1	21.1	22.1	23.0	24.0	25.0	26.0	28.3	29.3	30.4	31.4	32.5	33.5	34.6	35.6	36.7	37.7	38.8	39.8	40.9	41.9
	BE30F Lead 21	9.8	10.8	11.8	12.8	13.8	14.7	15.7	16.7	17.7	18.7	19.7	20.7	21.7	22.7	23.6	24.6	25.6	26.6	28.9	29.9	31.0	32.0	33.1	34.1	35.2	36.2	37.2	38.2	39.3	40.3	41.4	42.4
Type	Type																																
BE30E-BU-M21N-□□	15	25	35	45	55	65	75	85	95	A5	B5	C5	D5	E5	F5	G5	H5	J5	K5	L5	M5	N5	P5	Q5	R5	S5	T5	U5	V5	W05	W15		
BE30F-BU-M21N-□□	150	250	350	450	550	650	750	850	950	1050	1150	1250	1350	1450	1550	1650	1750	1850	1950	2050	2150	2250	2350	2450	2550	2650	2750	2850	2950	3050	3150		
BE30F-BU-M42N-□□	517	617	717	817	917	1017	1117	1217	1317	1417	1517	1617	1717	1817	1917	2017	2117	2217	2317	2417	2517	2617	2717	2817	2917	3017	3117	3217	3317	3417	3517		
Weight (kg)	BE30E Lead 21	10.5	11.5	12.5	13.5	14.4	15.4	16.4	17.4	18.4	19.4	20.4	21.4	22.4	23.3	24.3	25.3	26.3	28.6	29.6	30.7	31.7	32.8	33.8	34.9	35.9	37.0	38.0	39.1	40.1	41.2	42.2	
	BE30F Lead 42	11.1	12.1	13.1	14.1	15.0	16.0	17.0	18.0	19.0	20.0	21.0	22.0	23.0	23.9	24.9	25.9	26.9	29.2	30.2	31.2	32.3	33.4	34.4	35.5	36.5	37.6	38.6	39.7	40.7	41.8	42.8	

[NOTE] The format of the table lists only the end of the symbol "□□" part of the type. In the case of more than stroke 3000mm, it will be a three-digit code.

The values in parentheses are applicable when the stroke is 1850mm or over.

14

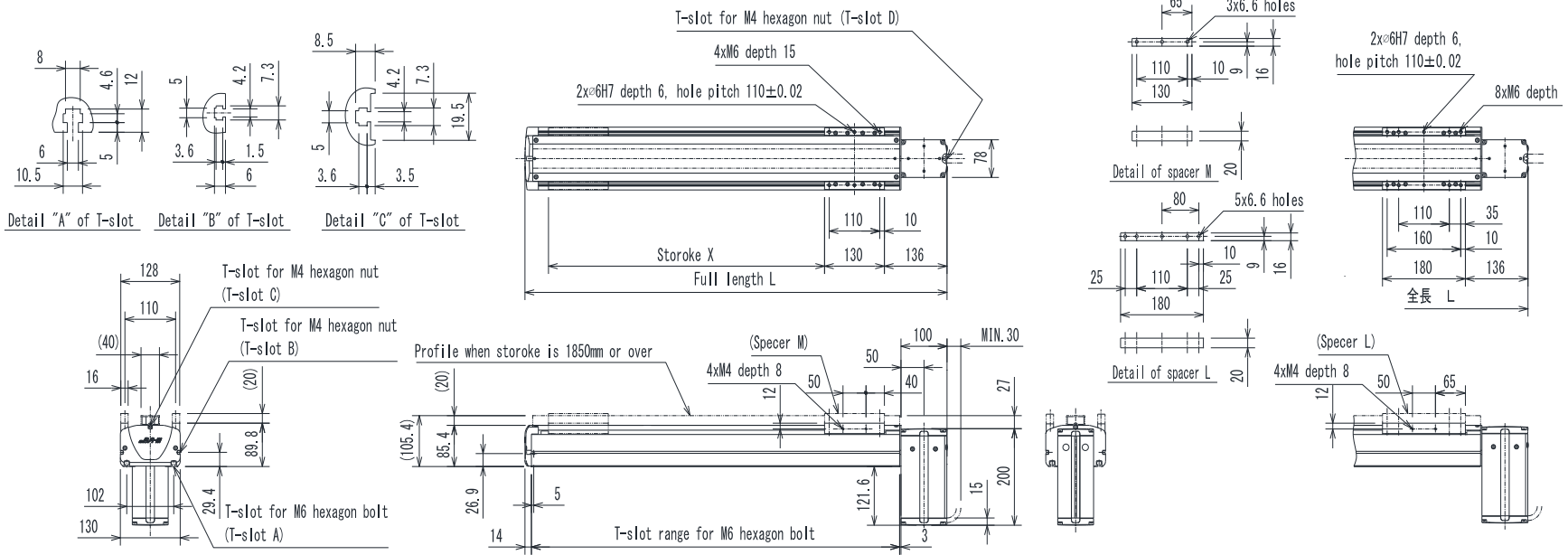

[BE30*-BU-M**N]

[BE30*-BU-L**N]

(3) Right side mounted motor axis [BE30*-BR-***N]

Type	Type																																	
BE30E-BR-M21N-□□	BE30F-BR-M21N-□□	BE30F-BR-M42N-□□	10	20	30	40	50	60	70	80	90	A0	B0	C0	D0	E0	F0	G0	H0	J0	K0	L0	M0	N0	P0	Q0	R0	S0	T0	U0	V0	W00	W10	W20
Stroke X (mm)	100	200	300	400	500	600	700	800	900	1000	1100	1200	1300	1400	1500	1600	1700	1800	1900	2000	2100	2200	2300	2400	2500	2600	2700	2800	2900	3000	3100	3200		
Full length L(mm)	417	517	617	717	817	917	1017	1117	1217	1317	1417	1517	1617	1717	1817	1917	2017	2117	2217	2317	2417	2517	2617	2717	2817	2917	3017	3117	3217	3317	3417	3517		
Weight (kg)	BE30E Lead 21	9.2	10.2	11.2	12.2	13.2	14.1	15.1	16.1	17.1	18.1	19.1	20.1	21.1	22.1	23.0	24.0	25.0	26.0	28.3	29.3	30.4	31.4	32.5	33.5	34.6	35.6	36.7	37.7	38.8	39.8	40.9	41.9	
	BE30F Lead 42	9.8	10.8	11.8	12.8	13.8	14.7	15.7	16.7	17.7	18.7	19.7	20.7	21.7	22.7	23.6	24.6	25.6	26.6	28.9	29.9	31.0	32.0	33.1	34.1	35.2	36.2	37.2	38.2	39.3	40.3	41.4	42.4	
	BE30F Lead 21	9.8	10.8	11.8	12.8	13.8	14.7	15.7	16.7	17.7	18.7	19.7	20.7	21.7	22.7	23.6	24.6	25.6	26.6	28.9	29.9	31.0	32.0	33.1	34.1	35.2	36.2	37.2	38.2	39.3	40.3	41.4	42.4	
Type	Type																																	
BE30E-BR-M21N-□□	BE30E-BR-M21N-□□	BE30F-BR-M21N-□□	15	25	35	45	55	65	75	85	95	A5	B5	C5	D5	E5	F5	G5	H5	J5	K5	L5	M5	N5	P5	Q5	R5	S5	T5	U5	V5	W05	W15	
Stroke X (mm)	150	250	350	450	550	650	750	850	950	1050	1150	1250	1350	1450	1550	1650	1750	1850	1950	2050	2150	2250	2350	2450	2550	2650	2750	2850	2950	3050	3150			
Full length L(mm)	517	617	717	817	917	1017	1117	1217	1317	1417	1517	1617	1717	1817	1917	2017	2117	2217	2317	2417	2517	2617	2717	2817	2917	3017	3117	3217	3317	3417	3517			
Weight (kg)	BE30E Lead 21	10.5	11.5	12.5	13.5	14.4	15.4	16.4	17.4	18.4	19.4	20.4	21.4	22.4	23.3	24.3	25.3	26.3	28.6	29.6	30.7	31.7	32.8	33.8	34.9	35.9	37.0	38.0	39.1	40.1	41.2	42.2		
	BE30F Lead 42	11.1	12.1	13.1	14.1	15.0	16.0	17.0	18.0	19.0	20.0	21.0	22.0	23.0	23.9	24.9	25.9	26.9	29.2	30.2	31.2	32.3	33.4	34.4	35.5	36.5	37.6	38.6	39.7	40.7	41.8	42.8		
	BE30F Lead 21	11.1	12.1	13.1	14.1	15.0	16.0	17.0	18.0	19.0	20.0	21.0	22.0	23.0	23.9	24.9	25.9	26.9	29.2	30.2	31.2	32.3	33.4	34.4	35.5	36.5	37.6	38.6	39.7	40.7	41.8	42.8		

[NOTE] The format of the table lists only the end of the symbol "□□" part of the type. In the case of more than stroke 3000mm, it will be a three-digit code.

The values in parentheses are applicable when the stroke is 1850mm or over.

15

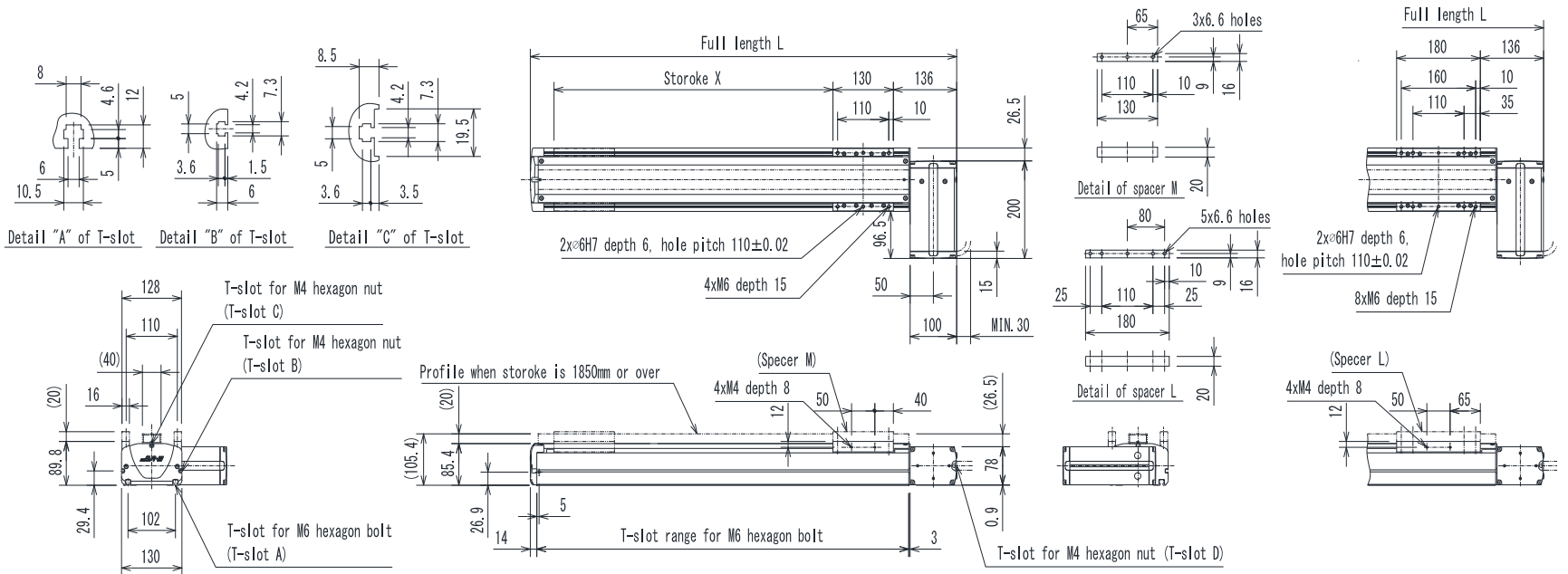

[BE30*-BR-M**N]

[BE30*-BR-L**N]

(4) Left side mounted motor axis [BE30*-BL-***N]

Type		Type																															
BE30E-BL-M21N-□□ BE30F-BL-M21N-□□ BE30F-BL-M42N-□□		10	20	30	40	50	60	70	80	90	A0	B0	C0	D0	E0	F0	G0	H0	J0	K0	L0	M0	N0	P0	Q0	R0	S0	T0	U0	V0	W00	W10	W20
Stroke X (mm)		100	200	300	400	500	600	700	800	900	1000	1100	1200	1300	1400	1500	1600	1700	1800	1900	2000	2100	2200	2300	2400	2500	2600	2700	2800	2900	3000	3100	3200
Full length L(mm)		417	517	617	717	817	917	1017	1117	1217	1317	1417	1517	1617	1717	1817	1917	2017	2117	2217	2317	2417	2517	2617	2717	2817	2917	3017	3117	3217	3317	3417	3517
Weight (kg)	BE30E Lead 21 BE30F Lead 42	9.2	10.2	11.2	12.2	13.2	14.1	15.1	16.1	17.1	18.1	19.1	20.1	21.1	22.1	23.0	24.0	25.0	26.0	28.3	29.3	30.4	31.4	32.5	33.5	34.6	35.6	36.7	37.7	38.8	39.8	40.9	41.9
	BE30F Lead 21	9.8	10.8	11.8	12.8	13.8	14.7	15.7	16.7	17.7	18.7	19.7	20.7	21.7	22.7	23.6	24.6	25.6	26.6	28.9	29.9	31.0	32.0	33.1	34.1	35.2	36.2	37.2	38.2	39.3	40.3	41.4	42.4
Type																																	
BE30E-BL-M21N-□□ BE30F-BL-M21N-□□ BE30F-BL-M42N-□□		15	25	35	45	55	65	75	85	95	A5	B5	C5	D5	E5	F5	G5	H5	J5	K5	L5	M5	N5	P5	Q5	R5	S5	T5	U5	V5	W05	W15	
Stroke X (mm)		150	250	350	450	550	650	750	850	950	1050	1150	1250	1350	1450	1550	1650	1750	1850	1950	2050	2150	2250	2350	2450	2550	2650	2750	2850	2950	3050	3150	
Full length L(mm)		517	617	717	817	917	1017	1117	1217	1317	1417	1517	1617	1717	1817	1917	2017	2117	2217	2317	2417	2517	2617	2717	2817	2917	3017	3117	3217	3317	3417	3517	
Weight (kg)	BE30E Lead 21 BE30F Lead 42	10.5	11.5	12.5	13.5	14.4	15.4	16.4	17.4	18.4	19.4	20.4	21.4	22.4	23.3	24.3	25.3	26.3	28.6	29.6	30.7	31.7	32.8	33.8	34.9	35.9	37.0	38.0	39.1	40.1	41.2	42.2	
	BE30F Lead 21	11.1	12.1	13.1	14.1	15.0	16.0	17.0	18.0	19.0	20.0	21.0	22.0	23.0	23.9	24.9	25.9	26.9	29.2	30.2	31.2	32.3	33.4	34.4	35.5	36.5	37.6	38.6	39.7	40.7	41.8	42.8	

[NOTE] The format of the table lists only the end of the symbol "□□" part of the type. In the case of more than stroke 3000mm, it will be a three-digit code. The values in parentheses are applicable when the stroke is 1850mm or over.

16

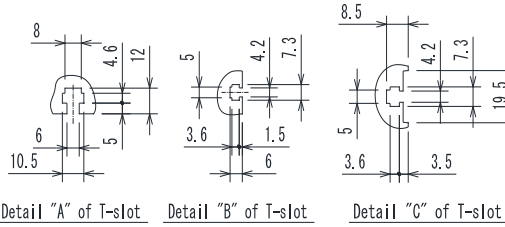

Detail "A" of T-slot Detail "B" of T-slot Detail "C" of T-slot

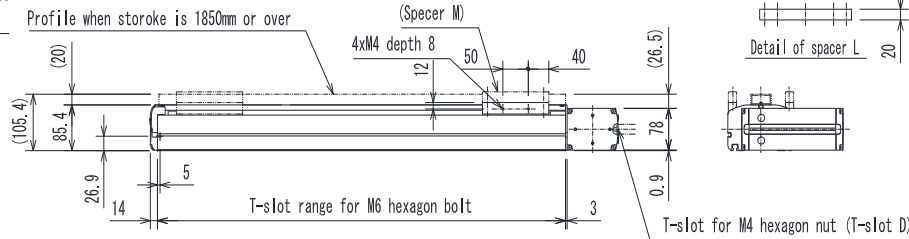
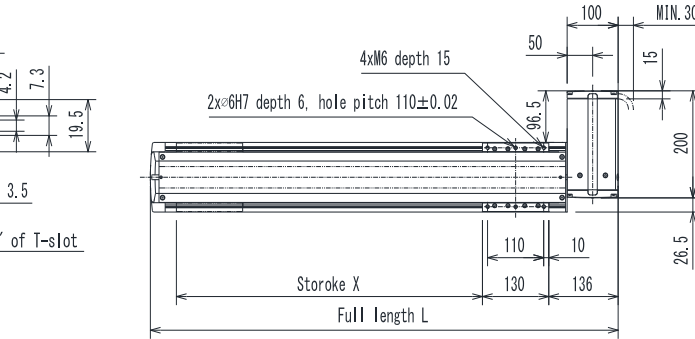
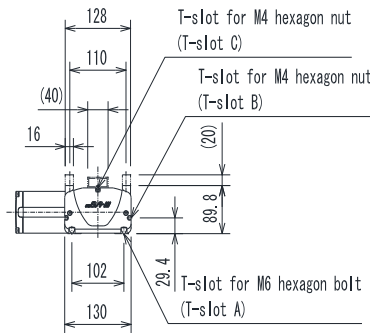

[BE30*-BL-M***N]

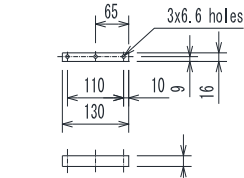

Detail of spacer M

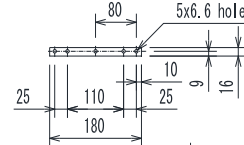

Detail of spacer L

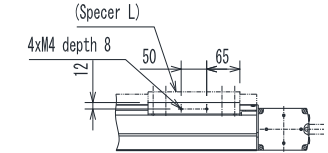
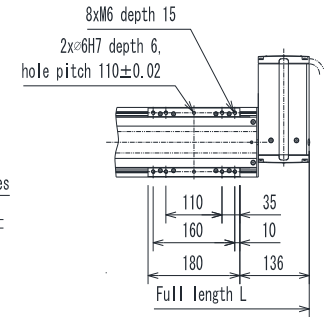

[BE30*-BL-L***N]

Chapter 4 Cable Installation

Install the cable according to the following procedure:

- (1) Loosen the four hexagon socket head button bolts holding the motor cover cap and remove the motor cover cap from the motor cover.

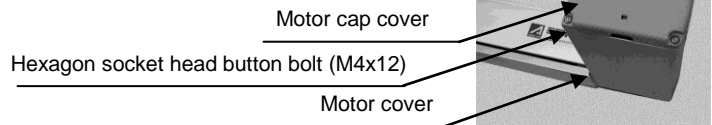

- (2) Select the cover of the cable outlet in the direction where the cable of the motor cover cap is pulled out, and hold it with cutting pliers. Then remove it by twisting.

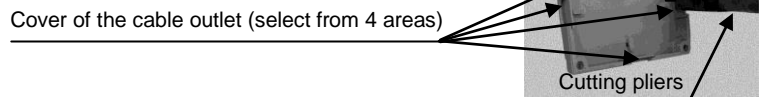

- (3) Insert a band into the lateral hole on the portion without the cover of the cable outlet of the motor cover cap.

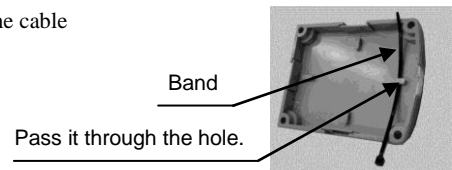

- (4) Use the band to fix the side of the controller cable which is fitted to the axis.
Do not tighten the band excessively.
Do not insert the cable excessively.

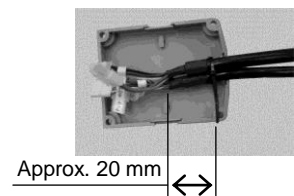

- (5) Attach the connector of the controller cable with the connector on the axis side and re-mount the motor cover cap on the motor cover. At the time of connection and fixing, take care not to allow undue force to be applied to the cable.
Do not allow the cable to be caught between the motor cover cap and motor cover.



Chapter 5 Installing Actuator (Axis)

- This chapter describes the basic installation procedures for the axis and peripheral equipment.
- Installation shall comply with the instructions of this Chapter. If the installation procedure is incorrect, robot performance cannot be achieved. Not only that, the service life may be seriously reduced.



CAUTION Precautions for installation

● Environment of installation site

(1) The ambient environment for operation shall comply with the following requirements:

- Ambient temperature Working temperature: 0°C to 40°C
Transportation and storage temperature: -10°C to 50°C
- Relative humidity: 30 to 90%RH without dew condensation
- Altitude: 1000 m or less
- Vibration 0.98 m/s² or less
- Dust: Free from conductive dust or dirt
- Gas: Free from flammable or corrosive gas
- Magnetic field: Free from a nearby device that may generate magnetic field
- Radiation: Not in the radiation controlled area
- Others: Without greasy fume

(2) This product is not designed as an explosion proof structure. Do not use it in a dusty place. Further, take sufficient care of the environment since it is not explosion-proof.

(3) Do not use it in a place with an organic solvent or white kerosene..
Of guide or ball screw grease is melted. It may cause malfunction.

● Precautions in installation

(1) Do not allow the product to fall down or be collided with other object during the transportation.

(2) Install the product where maintenance and inspection are easier.

(3) Install the controller within the range where it can be reached from the robot proper by a standard cable.

(4) Installation

- Install the product on a horizontal installation base.
- The installation base shall have the length that allows only the frame portion to be mounted.
- The installation base shall be made of a steel plate having a thickness of 9 mm or more where the plate has a machined surface with flatness of 0.2 or less. Install this product on this base to correct the bend and twist of the axis frame and to reinforce the axis frame.
- Install the oval bolts (installation bolts) of the axis at a pitch of approximately 150 mm.

■ 5.1 Installing Actuator (Axis)

Installation shall comply with the following procedures:

(1) Setting the oval bolt

From the axis end face, insert the oval bolt in the T-groove of the frame installation surface.

(2) Mounting on the installation base

Drill installation holes on the installation base of the carriage at a pitch of approximately 150 mm, and mount the product with oval bolts.

▲ CAUTION

- The T-grooves (for M4 nut) on the side and top of the frame are used to install the CN box and optical parts. Never use these T-grooves to mount the axis.
- The nut tightening torque shall be 5.3 N·m.

■ 5.2 Robot type for each Axis

The robot type is indicated by the 6-digit numerals specified for each robot type.

If this setting is made, various parameter values suited to the axis to be used can be automatically set. The input procedure is given in Section 4.2 of the CA25 Instruction Manual (Basic Part).

The major robot type for each axis is given in the following Table. The axis (new models) not described in the following Table are specified in the Actuator Instruction Manual.

When you want to use a combination of Axes, see the following Table for each axis.

(For example, in the X-Y combination where the X-axis belt has a lead of 21 mm with a motor output of 200 W, and when motor output is 100 W, the robot type will be 602280 for X-axis and 601090 for Y-axis.)

[Robot type for BE30]

- When used as a slider traveling type axis (in normal use)

	Lead (mm)	Type of axis	Robot type
BE30E	21	BE30E-B□-□21□-□□	601290
BE30F	21	BE30F-B□-□21□-□□	602090
	42	BE30F-B□-□42□-□□	602080



- When you have used the origin change sensor (optional) and set the home position to the side reverse to the normal side, input the robot type prior to change. After that, change the "Setting the motor rotating direction" in paragraph 2 of Section 13.4.5 described in the CA25 Instruction Manual (Basic Part) (Change it from 1 to 0).

CAUTION

- Setting the robot type allows the gain to be automatically set. Only when it is used in axis combination, the servo gain setting must be changed manually according to the combination specifications and first and second axis strokes. Further, the acceleration/deceleration time may have to be changed according to the specifications.

■5.3 Parameter values

The parameters of this product are available in two types -- parameter 1 and parameter 2 -- depending on the frequency of use. The relationship between each parameter and the robot type is illustrated below:

Setting the robot type allows the parameters on the circled portion on the left to be automatically changed.

■5.3.1 Values of parameter 1 for each robot type

This parameter has a higher frequency of use.

- Belt-driven axis (slider movable type)

Automatic setting	Robot type		601290	602090	602080
			(100 W, Lead 21)	(200 W, Lead 21)	(200 W, Lead 42)
	Software limit value (upper limit)		0000.00	0000.00	0000.00
	Software limit value (lower limit)		0000.00	0000.00	0000.00
○	Servo gain Position/Speed	Position	32	19	34
		Speed	35	30	50
	Pass area		200		
	Origin offset value		0000.00	0000.00	0000.00
	Sequence of Return to Origin		1 (Note)	1 (Note)	1 (Note)
	JOG speed	L(Low speed)	10	10	10
		H(High speed)	50	50	50
	JOG inching movement		0.01	0.01	0.01

(Note) The Sequence of Return to Origin varies according to the combination format, installation conditions and others. The customer is requested to set it in conformity to your operation conditions.

The initial value is common at "1" for all robot types. Thus, if there is no change, simultaneous origin return of all axes can be achieved.

■ 5.3.2 Values of parameter 2 for each robot type

- Belt-driven axis (slider movable type)

Automatic setting	Robot type		601290	602090	602080	
			(100 W, Lead 21)	(200 W, Lead 21)	(200 W, Lead 42)	
	Axis display		X	X	X	
	In position data value		0.05	0.05	0.05	
	Overflow data value		20000	20000	20000	
<input type="radio"/>	Feed forward data value		2000	2000	2000	
<input type="radio"/>	Direction of motor rotation		1	1	1	
<input type="radio"/>	Maximum speed		1000	2000	2000	
<input type="radio"/>	Return to origin speed	(L) Low speed	10	10	10	
		(M) Medium speed	50	50	50	
		(H) High speed	200	200	200	
<input type="radio"/>	Return to origin method		1	1	1	
<input type="radio"/>	Origin sensor logic		0	0	0	
	High speed return to origin position		20	20	20	
<input type="radio"/>	Lead		21.015	21.015	42.020	
<input type="radio"/>	Encoder division number		32768	32768	32768	
<input type="radio"/>	Encoder pulse multiplier		4	4	4	
	Encoder type (Note)		a	a	a	
	Task and axis combination		[1]	[0]	[0]	[0]
	Task order of priority		[1]	[1]	[1]	[1]
	Task coordinate table		999	999	999	999
	Task step number		5000	0000	0000	0000

(Note) The encoder type cannot be set in this robot type since setting for each axis is not available.
See Section 13.4.17 of the CA25 Instruction Manual (Basic Part).

Chapter 6 Precautions for Use

■ 6.1 Fluctuation in sliding resistance during long-term storage

The belt drive axis of the ROIBOT drives the slider by meshing between the timing belt and pulley.

When the ROIBOT has been stored or its operation has been suspended for a longer period of time (*1), the timing belt is kept curled at the meshing portion between the timing belt and pulley (or roller).

When the slider is subjected to sliding close to this curl, a fluctuation occurs to the sliding resistance, but this does not raise any problem.

This curl does not affect the timing belt. Further, the fluctuation in the sliding resistance of the slider does not have any adverse effect on the repeated positioning accuracy.

The curl of the timing belt will be removed after several days of operation (*2). The fluctuation in the sliding resistance due to the curl of the belt will also be removed.

For the bend of the timing belt, see Section 7.6 Routing the timing belt.

*1: About a week. This may vary according to the environment during storage.

*2: The number of days of operation before the curl of the timing belt is removed varies according to the number of reciprocations of the slider per day and the storage period.

■ 6.2 In the event of collision

Skipping of teeth may occur to the meshing between the belt and pulley by the collision between the slider and axis end due to some trouble. If this occurs, the origin and working range will be misaligned.

In this case, the axis must be readjusted. Retighten the belt. For the belt tightening procedure, see Section 7.5 Timing belt and motor replacement procedure.

Chapter 7 Maintenance

■ 7.1 Precautions for inspection and maintenance work

(1) Precautions for inspection and maintenance work

Observe the following instructions at the time of inspection and maintenance:

1. The robot shall be inspected and maintained by the personnel having a sufficient level of skill and experience. If such personnel are not available, contact the manufacturer and request implementation of the relevant work or education of the person in charge.
2. Use adequate illumination.
3. The start switch of the stationary operation panel or some other similar portion shall be provided with a notice board to indicate that the inspection and maintenance work is currently in progress. Before entering the fence and enclosure, lock the open power switch to turn off power completely. If the access of the fence or enclosure is provided with a safety plug, be sure to carry the related plug with you.
4. If you have to enter the fence and enclosure for inspection and inspection of the control circuit, turn off the drive power source.
5. If you have to operate the industrial robot in the inspection and maintenance work within the guard fence and enclosure, you are recommended to take the following measures:
 - Two persons should be engaged in the work in cooperation with each other. This means that role assignment should be made in such a way that one person supervises the work of the other person during the work.
 - It is required to select such a speed that contact with the robot can be avoided in the event of a possible operation error of the robot. Determine the speed suited for the relevant work.
 - Take care of the robot operation during the work. Press the emergency stop button immediately when an unexpected operation has been detected.
6. Before starting disassembly of the pressure gauge or replacement of the parts, release the residual pressure of the cylinder.
7. Before starting disassembly of the hydraulic and pneumatic systems or replacement of parts, take a sufficient care to avoid deposition or mixture of foreign substances such as dust.

(2) Action to be taken subsequent to inspection and maintenance work

1. After termination of the inspection or maintenance work, the inspection or maintenance worker shall carry the tools back to the original position.
2. After termination of the maintenance work, be sure to perform a test run to verify the result. The test run shall be performed from outside the fence and enclosure in principle.
3. After action of item 2 has been taken, the inspection or maintenance worker shall report termination of the inspection or maintenance work to his superior.

■ 7.2 Inspection before starting the work

- (1) Before starting your work with the robot, make sure of the following:
 1. Brake device function
 2. Emergency stop device function
 3. Contact preventive equipment and robot interlock function
 4. Related devices/robot interlocking function
 5. Possible damage of the external wiring and piping
 6. Error of supply voltage and hydraulic and pneumatic pressures
 7. Operation error
 8. Abnormal noise and vibration
 9. Contact preventive equipment state

- (2) This inspection shall be conducted outside the movable range wherever possible.

■ 7.3 Periodic inspection

Giving consideration to the robot installation site, frequency of use and durability of the parts, determine the inspection standards including the inspection item, inspection procedure, evaluation criteria and implementation period for the following items. Start inspection in conformity to these standards.

1. Looseness of major parts
2. Lubrication and other possible errors of the movable parts
3. Power transmission component trouble
4. Hydraulic and pneumatic system error
5. Electric system error
6. Operation failure detecting function error
7. Encoder error
8. Servo system error

■ 7.3.1 Timing belt inspection

Inspect the timing belt at intervals of approximately 500 hours.

- Check the belt for deterioration, fatigue and scratches. Replace it if any problem has been detected. For the replacement procedure, see the Actuator Instruction Manual.
- If you want to use the brake motor shuttling axis in the vertical position (as a Z-axis), observe the following instructions:
 1. Be sure to replace the belt before operation for 3000 hours.
 2. The service life of the belt heavily depends on the working environment and conditions. If any trouble has been found out during the inspection, replace the belt immediately.



If the belt used in the vertical position is broken, a serious accident may occur.
Enforce belt replacement in good time.

■7.4 Cleaning

Clean the robot proper in conformity to the following steps:

1. Turn off the power switch and remove the power plug.
2. Use waste cloth or such to remove the dust and dirt from the frame and covers etc.
3. Remove the frame cover and clean the dust and dirt from the frame cover. After that, supply oil for lubrication.
4. Mount the frame cover back.

■7.5 Timing belt and motor replacement procedure

Replace the timing belt and motor in conformity to the following steps:

For the belt tension adjustment procedure, see Section 7.6 Routing the timing belt as well.

⚠ CAUTION

- Turn OFF power before starting the work.
- When the belt tension has been adjusted, the programmed position (teaching position) may be misaligned. If it is misaligned, correct the programmed position (teaching position).

(1) Remove the cover.

(When you want to replace the motor for the 21 mm-lead product alone, you need not remove the frame cap or end plate.)

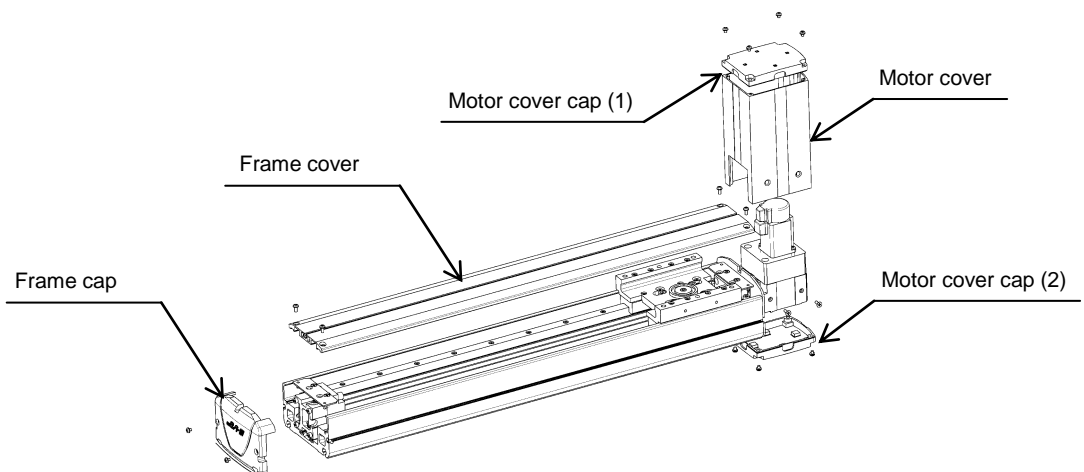

- (2) Loosen two belt clamp bolts and reduce the timing belt tension.
 (This step is not necessary if you want to replace the motor for the 21 mm-lead product alone.)
 When the motor faces leftward, remove the frame cover mounting plate from the end base and loosen the belt clamp bolt from the hole of the end base.

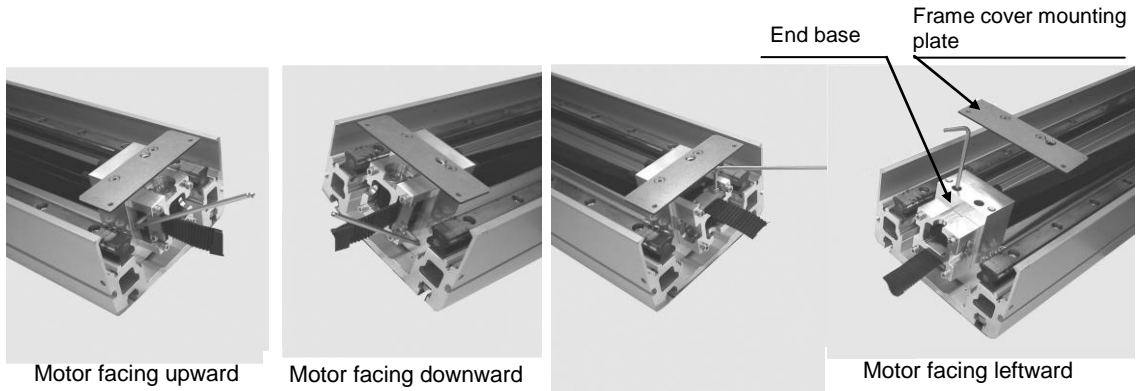

- (3) Loosen the bolt on the motor output shaft side of the coupling located inside, from the hole of the motor spacer.
 (For the 42 mm-lead product, this work is not necessary.)

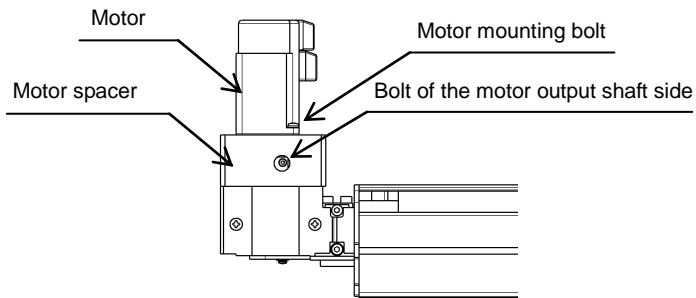

- (4) Remove the motor mounting bolt. Then remove the motor (21 mm-lead product with inertia damper, 42 mm-lead product with pulley and bearing) from the axis.
 If you want to replace the motor alone, go to step (12).

- (5) Remove the belt clamp proper from the motor block.
- For 21 mm-lead product
 Loosen the motor spacer mounting screw, and remove the motor spacer from the motor block.
 Loosen the belt clamp mounting screw on the motor block side and remove the belt clamp proper from the motor block.

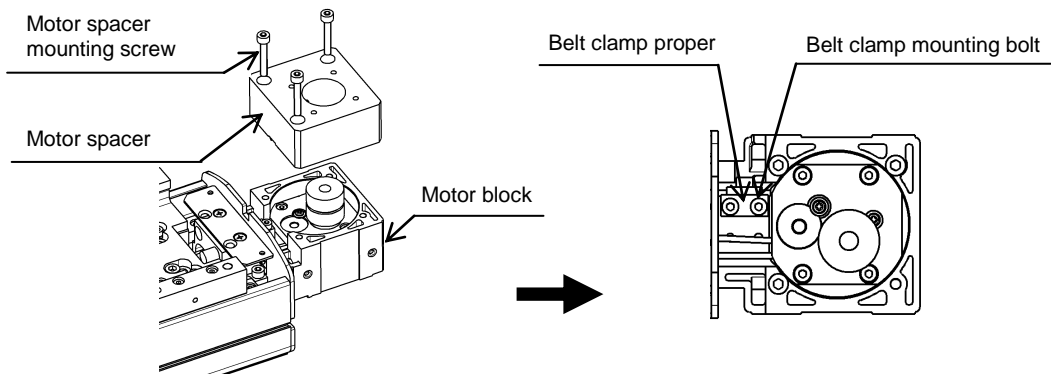

- For 42 mm-lead product
Loosen the belt clamp mounting screw on the motor block side and remove the belt clamp proper from the motor block.

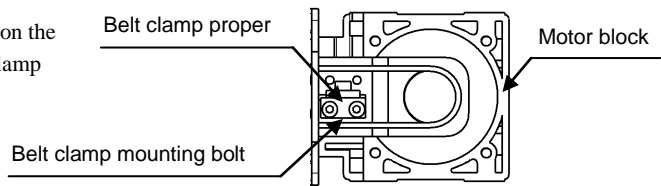

- (6) Remove the screw of the sheet metal fixing the belt of the belt clamp on the motor block side. Then remove the belt.
- (7) Pull the end of the belt and remove the belt from the axis.
- (8) Pull out the prepared belt from the motor block and mount it again on the belt clamp. Fix the belt so that it will be protruded one thread from the belt clamp.

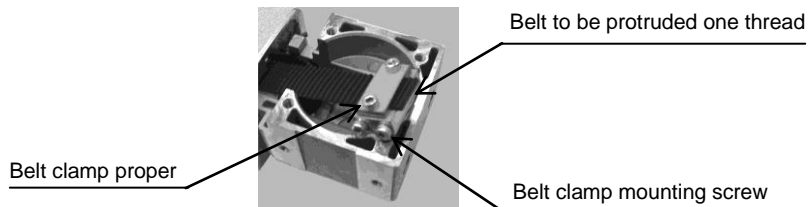

- (9) The belt clamp proper on the motor block side shall be mounted on the motor block.
(Tapped hole outside the motor block outside for 21 mm-lead product, and tapped hole at the center of the motor block outside for 42 mm-lead product; See 7.5(5))
- (10) Route a new timing belt in the order of the slider block (motor side), inside the motor block, end block, slider block (end side) and end side belt clamp proper. It should be noted that routing of the motor varies according to the motor mounting direction and lead (See 7.6).

- For 21 mm-lead product
Loosen the motor bracket mounting screw and remove the motor bracket from the motor block. If the belt has been routed, mount the motor bracket on the motor block
(See 7.6.1).

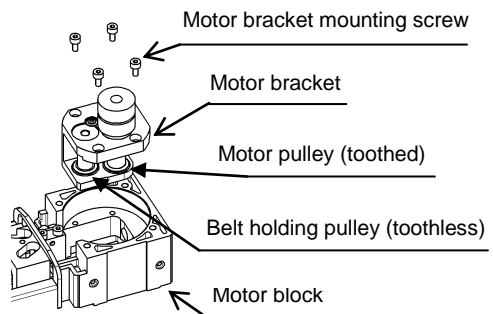

- For 42 mm-lead product
Turn back the timing belt within the motor block so that it can be applied to the pulley (See 7.6.2).

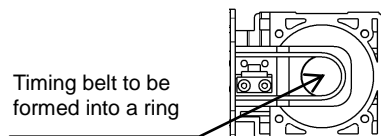

CAUTION

Do not allow the belt to be twisted.

- (11) For the 21 mm-lead product, mount the motor spacer on the motor block.
(The 42 mm-lead product is not provided with a motor spacer).

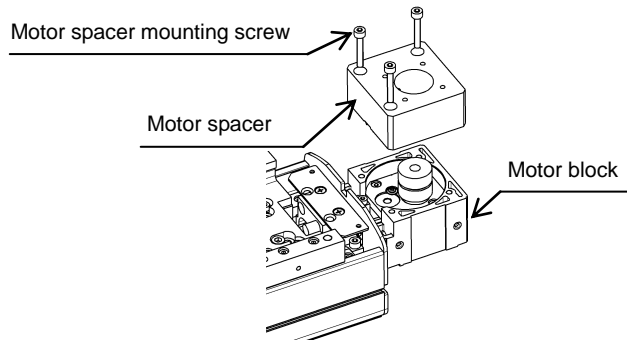

- (12) Connect the motor with the controller on the temporary basis. Then connect the teaching pendant to the controller, and return the axes to the origin.
- (13) The motor rotates. Taking care not to touch the rotating part, move the slider close to the origin. If the origin sensor has detected the slider, the motor starts the stop operation at the time of return to the origin.
- (14) After the motor has stopped (completion of return to origin), move the slider so that the distance between the slider and plate will be 34 mm.

Turn off the controller power and mount the motor on the motor block using the original screw.

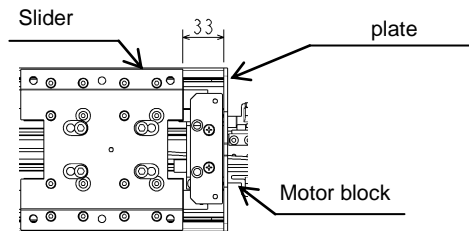

- (15) Tighten the motor mounting screws uniformly little by little so the motor will not be tilted. The motor lead wire should be oriented toward the slider.

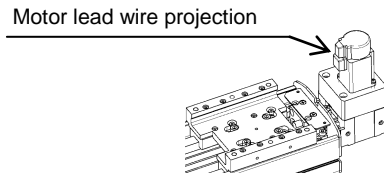

- (16) Mount the motor on the motor block, and loosen four bearing clamping plate screws on the bottom of the motor block. Make sure that the bearing clamping plate rotates a little about the bearing. After that, uniformly retighten bearing clamping plate mounting screws having been loosened. Make sure that there is no misalignment between the motor mounting position and bearing clamping plate. (For the 21 mm-lead product, this work is not necessary).

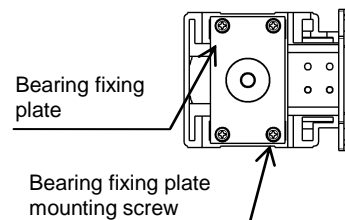

- (17) Adjust the meshing between the peak and valley of the end of the belt protruding from the belt clamp on the end block side, and bind them with a band.

Meshing between the peak and valley of the belt

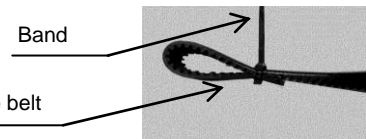

- (18) Route the hook of the spring balance through the portion where the timing belt has been turned back.
Pull the timing belt with a force of 147 N (15 kgf).
When the belt is kept pulled, tighten the belt clamp bolt

Belt clamp bolt

Spring balance

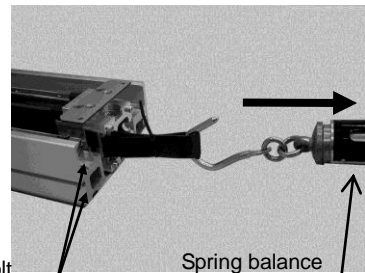

- (19) Mount the cover.

CAUTION

- A new timing belt may be subjected to initial elongation. When the initial elongation occurs and the belt tension has been reduced, set the belt tension back to the specified level.
- When the belt has been re-tightened, the programmed position (teaching position) may be misaligned. If this has occurred, correct the program (teaching).

7.6 Routing the timing belt

For the details of the motor block interior, see Section 7.5 (10).

Route the timing belt so that the belt tooth will touch the toothed pulley and the back of the belt will touch the toothless pulley.

Take care to make sure of the directions of the motor block, end block and slider block.

7.6.1 Routing the timing belt for 21 mm-lead product

- Schematic view

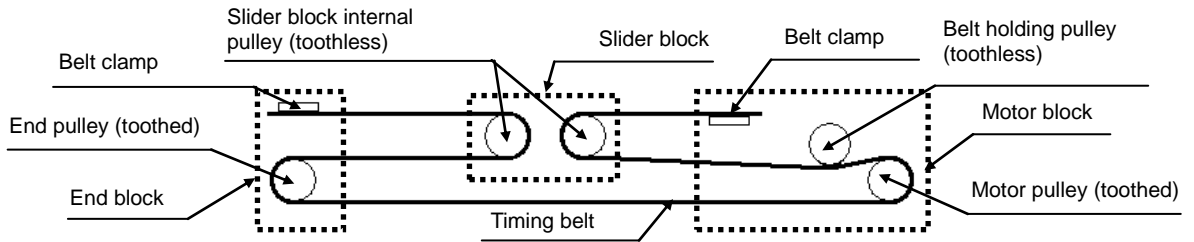

- Motor facing upward

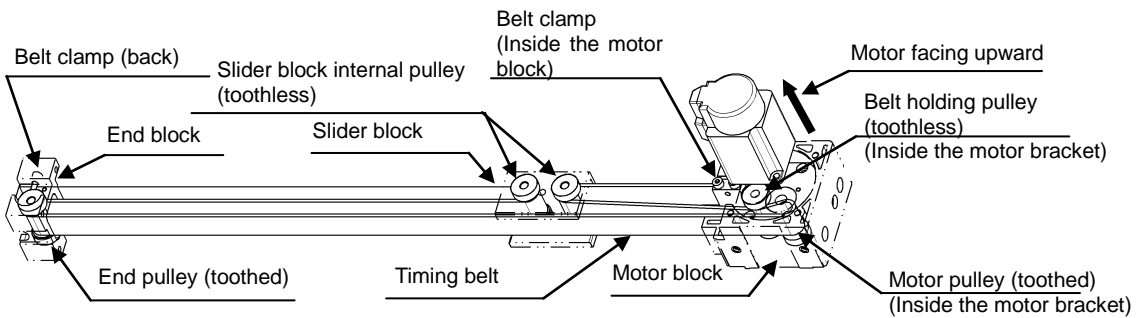

- Motor facing downward

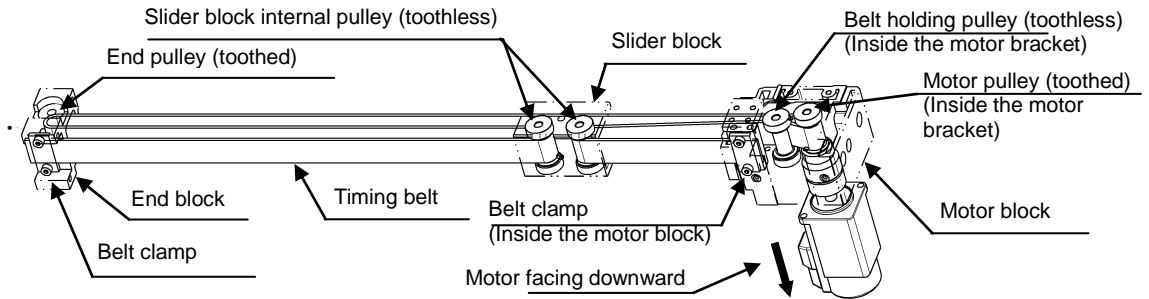

- Motor facing rightward

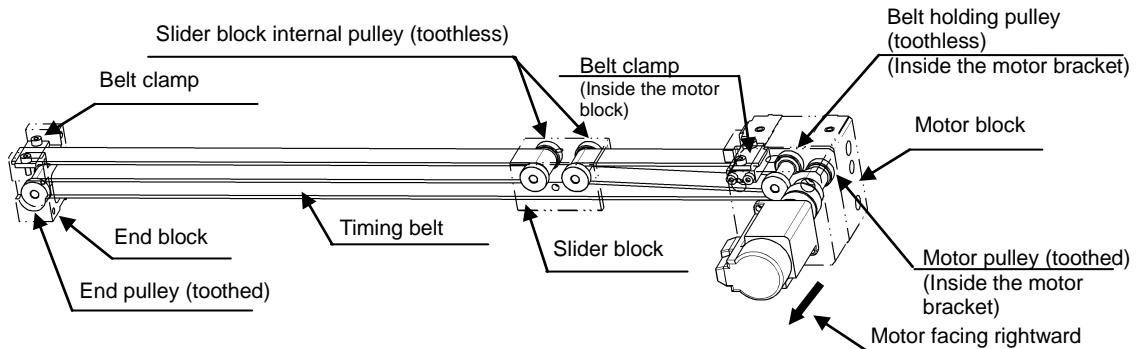

- Motor facing leftward (The end side belt clamp is located inside the end base.)

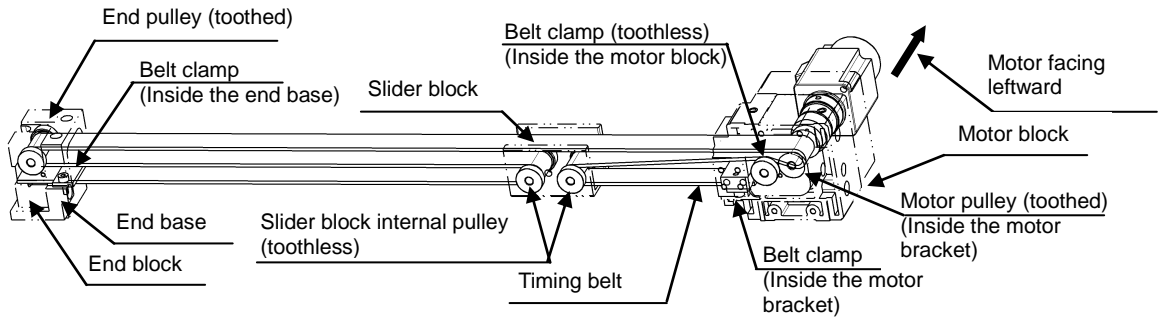

7.6.2 Routing the timing belt for 42 mm-lead product

- Schematic view

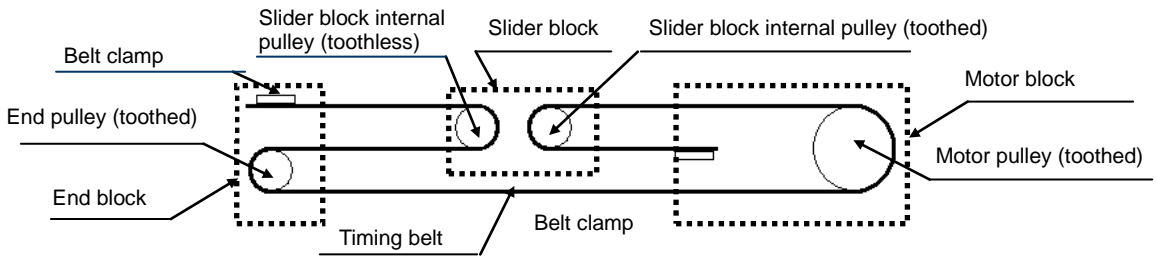

- Motor facing upward

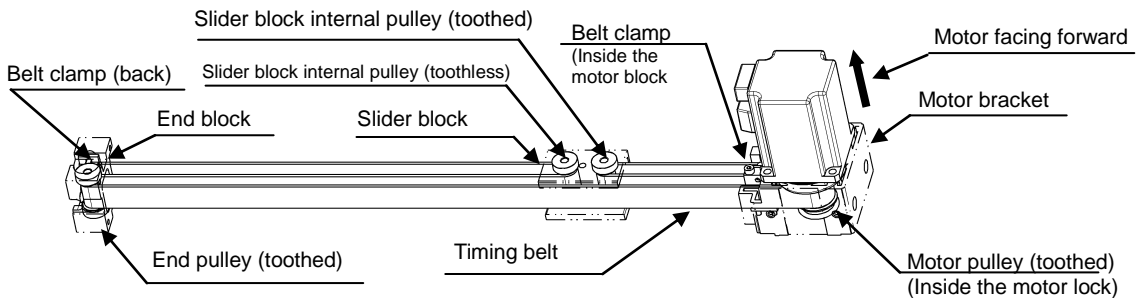

- Motor facing downward

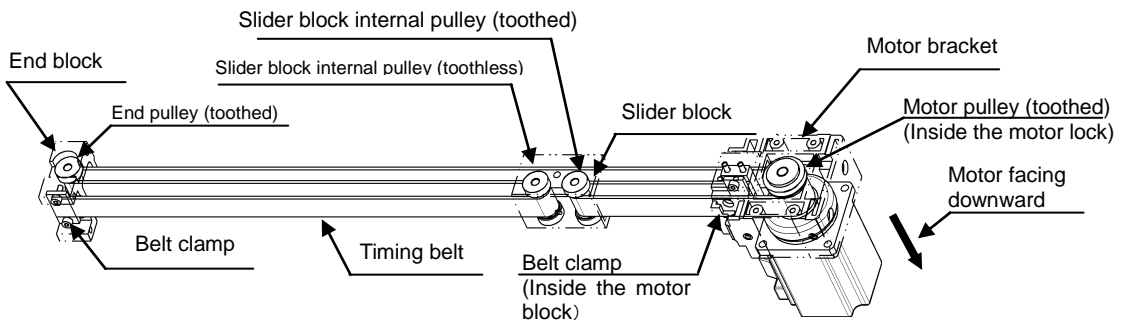

- Motor facing rightward

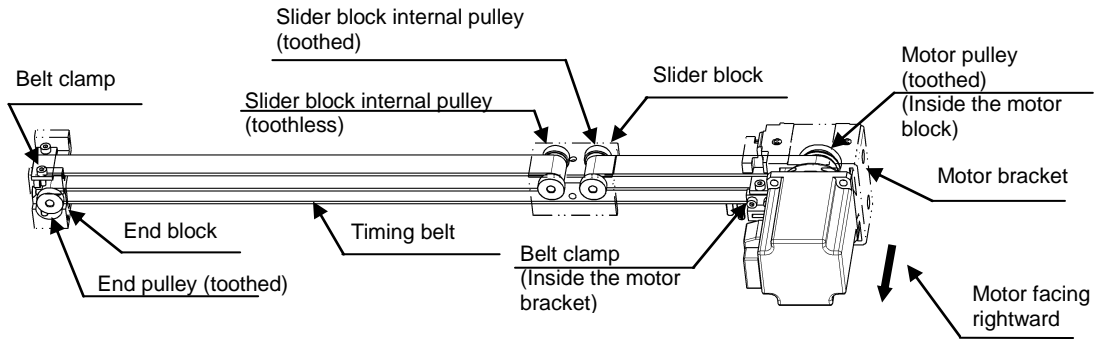

- Motor facing leftward (The end side belt clamp is located inside the end base.)

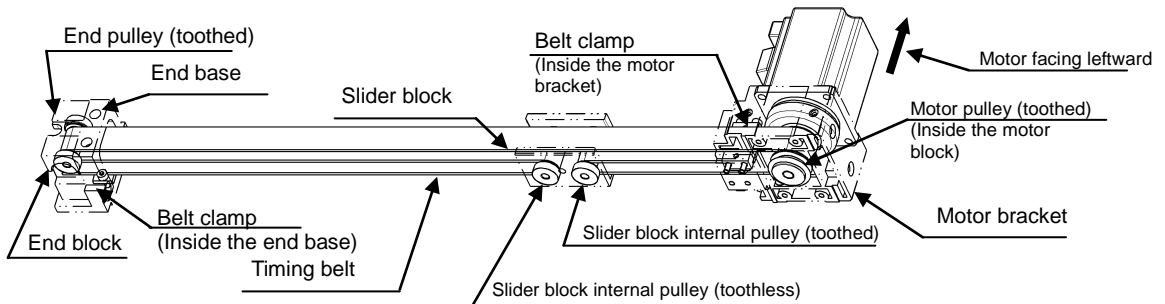

7.7 Origin position adjustment

Adjust the home position by the distance between the origin sensor and motor block.

The distance between the origin sensor and motor block is “A”.

Applicable axis	A
BE30E(F)-B*-M	50mm
BE30E(F)-B*-L	100mm

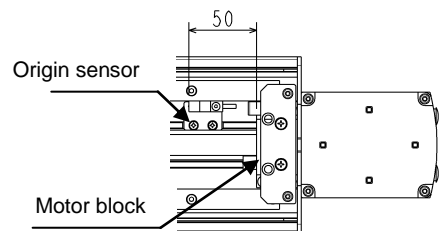

7.8 Linear guide replacement

- If the linear guide needs to be replaced, contact our sales office closest to your company.
It must not be replaced by the customer.
- This replacement is performed for each axis. It should be noted that this replacement cannot be made inside the device or in the combined state.

7.9 Greasing

- Greasing positions

The linear guide of this product are provided with an oilless seal. To prevent a possible accident, check for the greasing conditions and damages on a periodic basis. If insufficient lubrication has been found out, supply grease according to the following steps. If any trouble such as a breakdown has been detected and repair work is required, contact the Service Divisions shown at the end of this Manual, and request repair to be made.

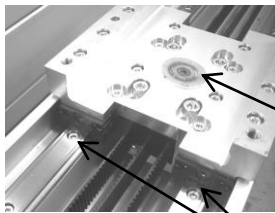

Supply grease into the concave portion. BE30
For the product having an stroke of 1850mm or more

Linear guide

Greasing position	Type of grease (manufacturer)	Inspection and greasing intervals	Volume of grease
Linear guide	Albania Grease S2 (Shell)	Every 6 months	A thin layer of grease applied on the linear guide rail
Resin on slider			Fill the groove.

- Inspection and greasing steps

1. Turn off the power and remove the power plug.
2. Remove the frame cover of the axis.
3. Inspect the linear guide . If insufficient greasing has been found out, supply grease to the above-mentioned greasing positions.
4. Slowly move the slider manually or in the jog mode (at a speed of about 50 mm per second or less) five or more reciprocations and make sure that grease has been supplied into the linear guide block.
5. Wipe off the overfilled or discolored grease.
6. Mount the frame cover again.

CAUTION

If the fats and oils in the belt is attached, please be sure to wipe it will be the cause of the deterioration of the belt.

Chapter 8 Spare Parts

When a trouble has occurred to the robot proper and you have found it out at an earlier stage, you cannot repair it if you have no repair parts. Accordingly, you are recommended to keep spare parts on hand.

No.	Parts name	Remarks
1	Timing belt	Varies according to the stroke. Contact our Service Division.
2	AC servo motor (encoder: absolute)	With a 21 mm-lead pulley (100 W)
3	AC servo motor (encoder: absolute)	With 21 mm-lead inertia damper (200 W)
4	AC servo motor (encoder: absolute)	With 42 mm-lead pulley (200 W)

TOSHIBA MACHINE CO.,LTD. HEAD OFFICE

Electronic Equipment Sales Group, Control Systems Division
2068-3, Ooka, Numazu-shi, Shizuoka-ken 410-8510, Japan
TEL: [81]-(0)55-926-5032 FAX: [81]-(0)55-925-6527

TM ROBOTICS (AMERICAS) INC.

755 Greenleaf Avenue, EIK Grove Village, IL 60007, U.S.A.
TEL:[1]-847-593-1616 FAX:[1]-847-593-0897

TOSHIBA MACHINE (THAILAND)CO.,LTD.

127/28 Panjathanee Tower, 23th Floor, Nothree Road, Khwaeng
Chong Nonthree, Khet Yannawa, Bangkok 10120, THAILAND
TEL: [66]-(0)2-681-0158 FAX: [66]-(0)2-681-0162

TM ROBOTICS(EUROPE) LTD.

Unit 2, Bridge Gate Centre,
Martinfield, Welwyn Garden City, Herts AL7 1JG UK
TEL: [44]-(0)1707-290370 FAX: [44]-(0)1707-376662

URL: <http://www.toshiba-machine.co.jp/seiji/prod/sr>

<http://www.tmrobotics.com>

<http://www.tmrobotics.co.uk>