

The P point's move envelope

The P point is cross of J5 and J6 axis.

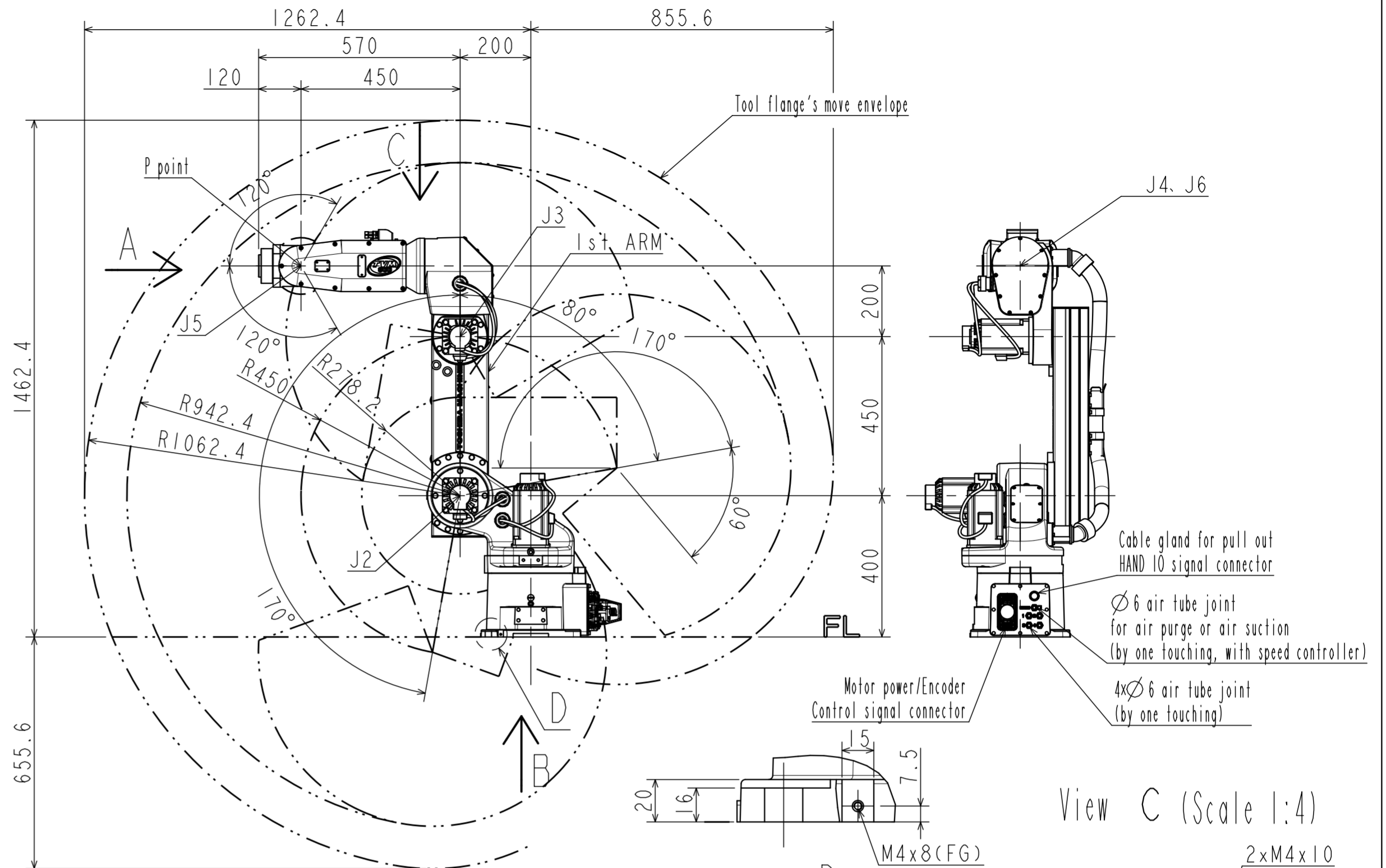

T-groove dimension (Scale 1:4)

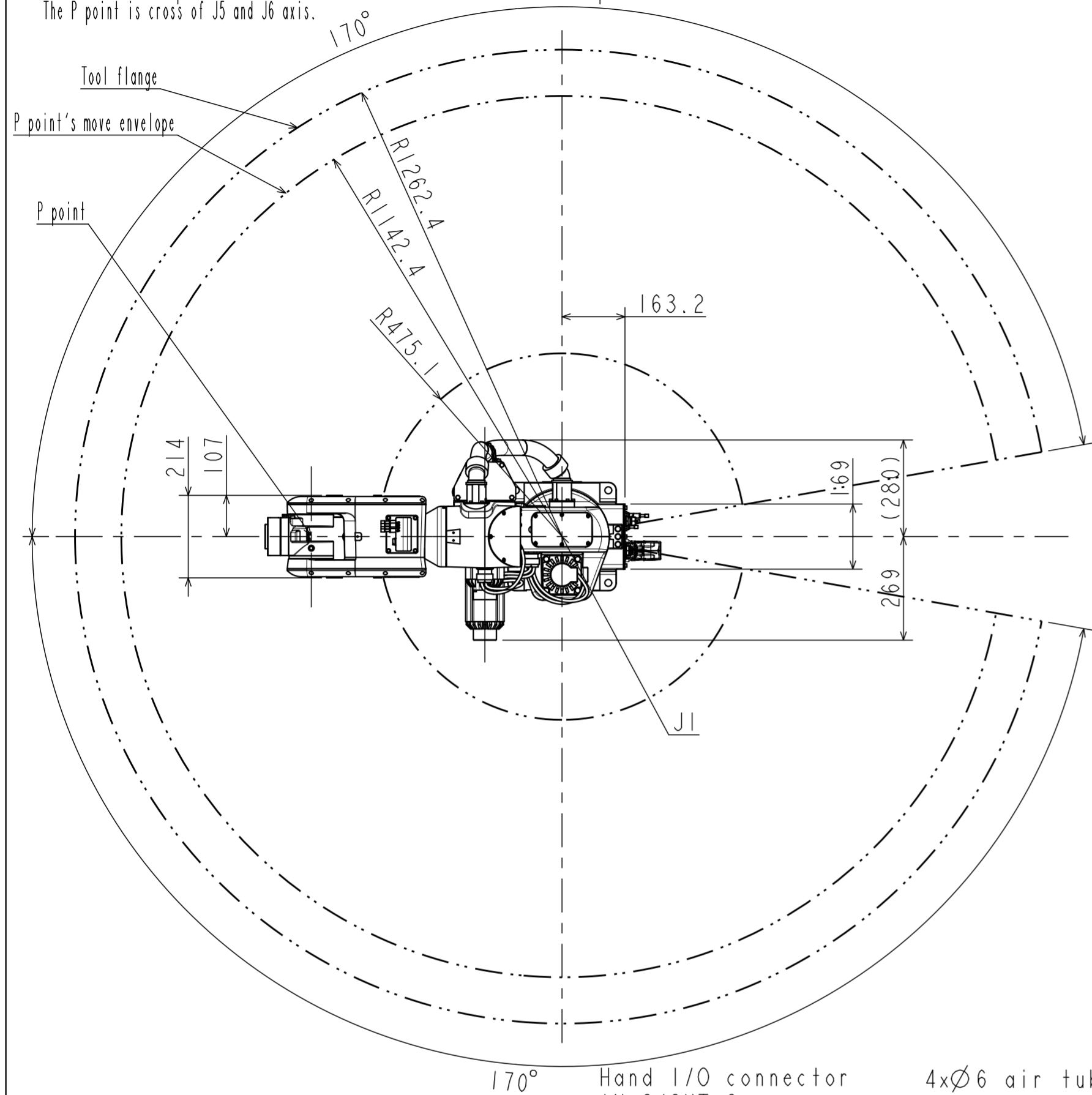
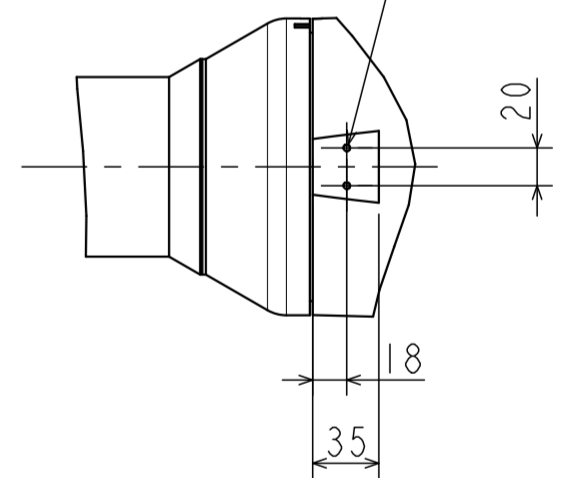
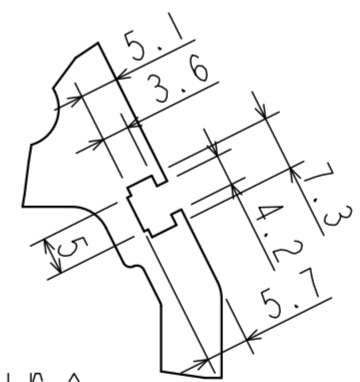
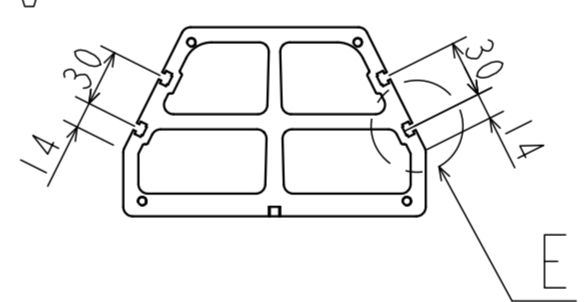

Detail of tool flange View A (Scale 1:4)

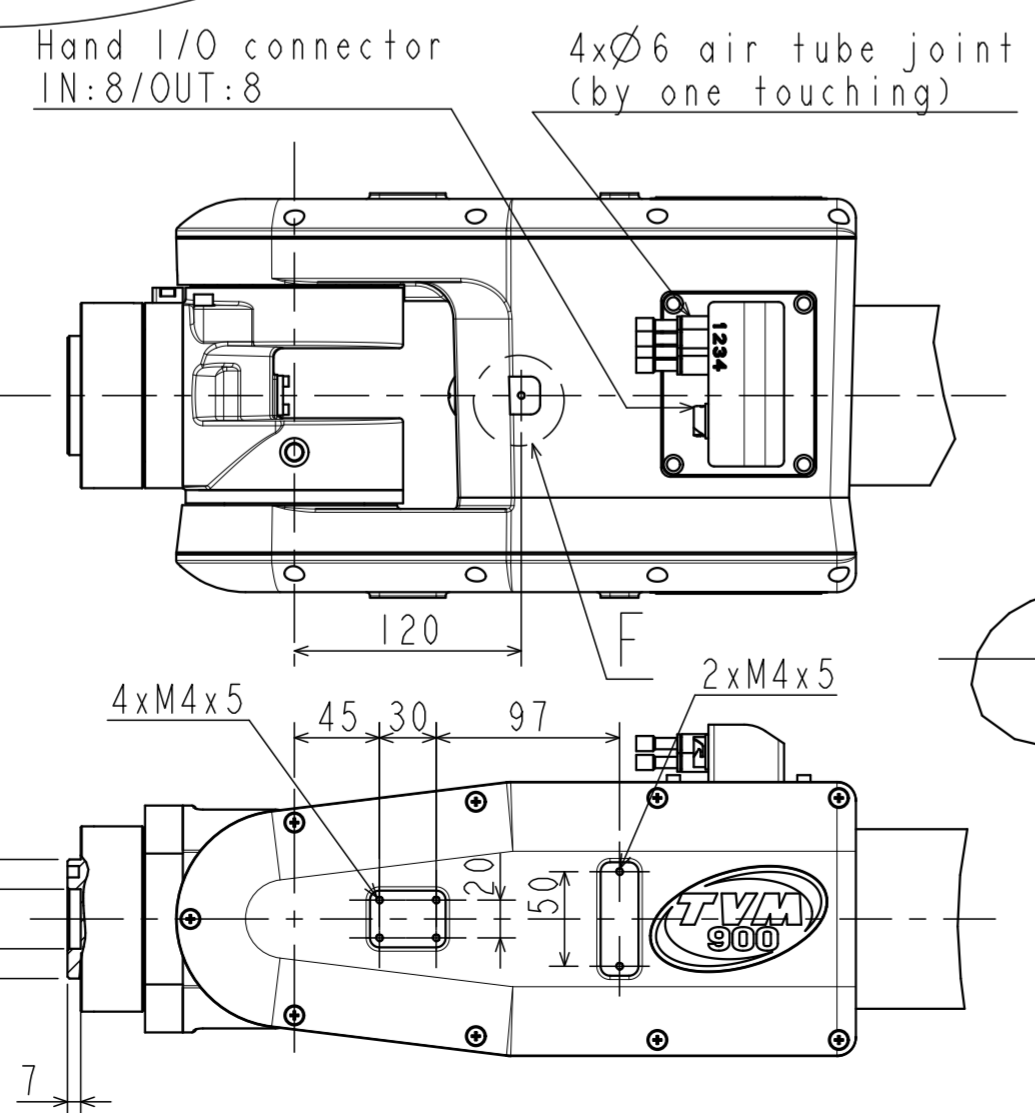
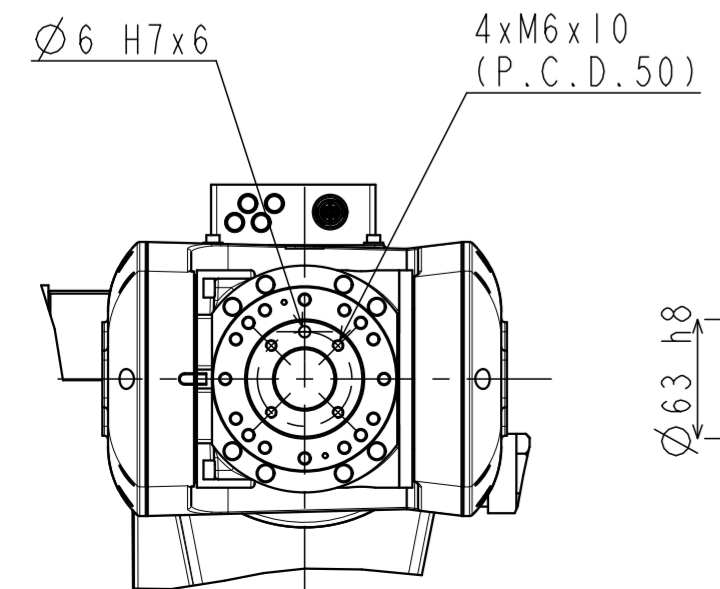

Detail of base fixture View B (Scale 1:4)

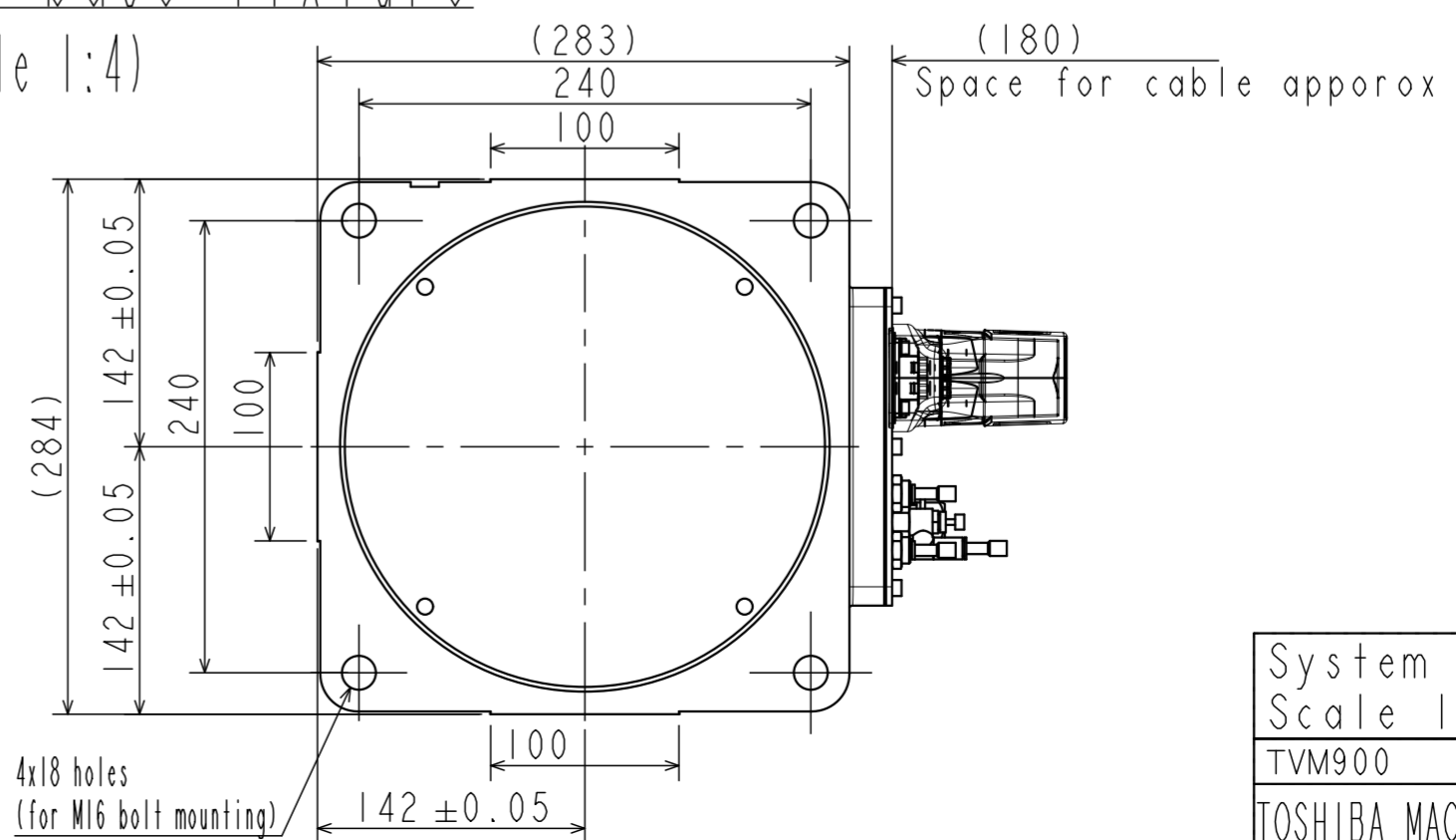

Joint	Moving envelope(deg)
J1	±170
J2	+170~-80
J3	+170~-60
J4	±190
J5	±120
J6	±360

The orientation in this drawing is 90° for J3 only and 0° for other axes.